

# RKM Series

## User's Guide



### Models

RKM-PS2, RKM-USB

- With KVM options



### Models

RKM-PS2-SD, RKM-USB-SD

- Short depth version
- Without KVM options

© 2007 **Avenview Inc.** All rights reserved.

The contents of this document are provided in connection with Avenview Inc. ("Avenview") products. Avenview makes no representations or warranties with respect to the accuracy or completeness of the contents of this publication and reserves the right to make changes to specifications and product descriptions at any time without notice. No license, whether express, implied, or otherwise, to any intellectual property rights is granted by this publication. Except as set forth in Avenview Standard Terms and Conditions of Sale, Avenview assumes no liability whatsoever, and disclaims any express or implied warranty, relating to its products including, but not limited to, the implied warranty of merchantability, fitness for a particular purpose, or infringement of any intellectual property right.

Reproduction of this manual, or parts thereof, in any form, without the express written permission of Avenview Inc. is strictly prohibited.

## Table of Contents

Section 1 – Getting Started .....	3
Package Contents.....	3
Before Installation.....	4
Unpacking.....	4
Optional Accessories .....	4
Peripheral Products.....	5
Structure Diagram .....	5
Installation.....	6
Section 2: Keyboard & Mouse.....	7
Section 3: KVM Options for RKM-PS2 & RKM-USB .....	8
Section 4: Dimensions.....	8

## Section 1 – Getting Started

### Package Contents

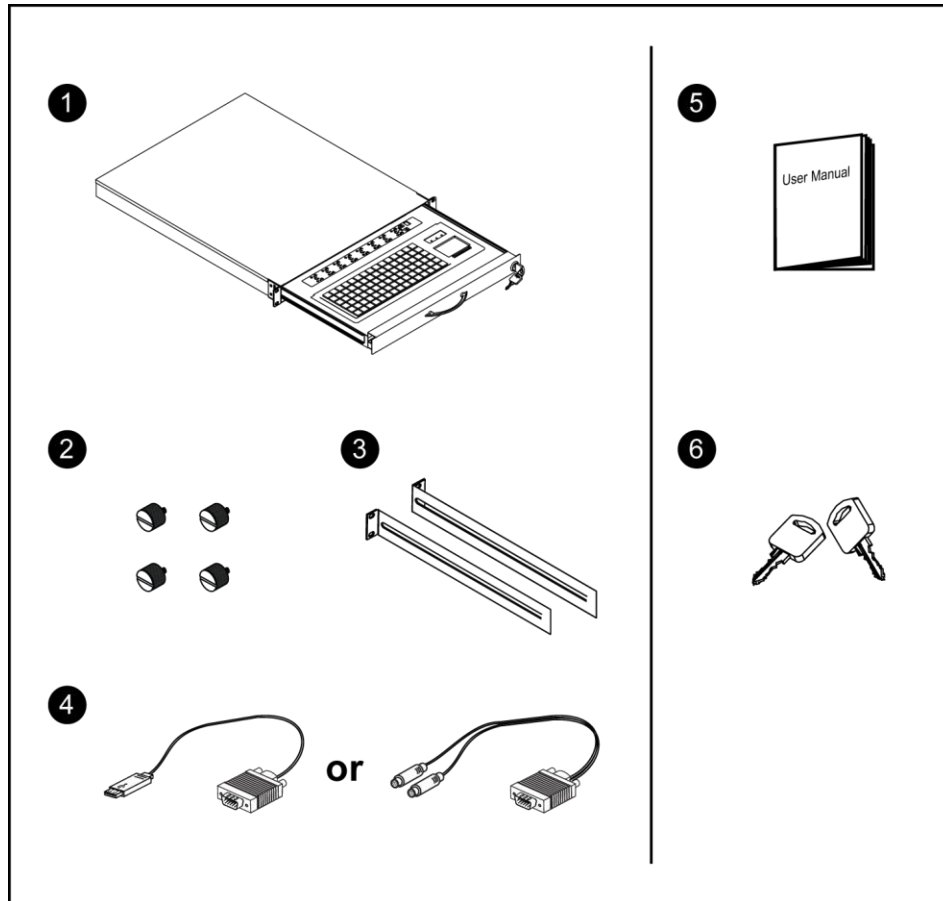

- ① Keyboard drawer x 1 pc,
- ② Fasteners for rear L-bracket x 4 pcs
- ③ 330mm rear mounting L-bracket x 1 pair
  - RKM-PS2 & RKM-USB Series mounting depth-adjustable from 220 to 820mm
  - RKM-PS2-SD & RKM-USB-SD Series maximum mounting depth is 660mm
- ④ USB keyboard cable x 1 pc **or** 2-in-1 PS/2 keyboard cable x 1 pc
- ⑤ User manual x 1 pc
- ⑥ Key x 2 pcs

## Before Installation

- It is very important to locate the Rackmount Keyboard Drawer in a suitable environment.
- The surface for placing and fixing the Rackmount Keyboard Drawer should be stable and level or mounted into a suitable cabinet.
- Make sure the place has good ventilation, is out of direct sunlight, away from sources of excessive dust, dirt, heat, water, moisture and vibration.
- Convenience for connecting the Rackmount Keyboard Drawer to the related facilities should be well considers too.

## Unpacking

The Rackmount Keyboard Drawer comes with the standard parts shown on the package contents. Check and make sure they are included and in good condition. If anything is missing, or damage, contact the supplier immediately.

## Optional Accessories

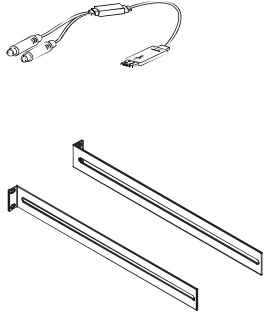
<p><b>1. SUN / iMAC USB to PS/2 adapter</b> 1.1 SUN-31</p> <p><b>2. Extended rear mounting L-bracket</b> 2.1 430mm (16.9") extended rear L-bracket for : RKM-PS2, RKM-USB up to 920mm RKM-PS2-SD, RKM-USB-SD series up to 740mm *Extended rear L-bracket in tailor-made length on request</p>	
---	---

## Peripheral Products

Item	Description
<b>DB-15 KVM</b>	8 / 16-port IP PS/2 KVM 8 / 16-port two console PS/2 KVM 4 / 8 / 16-port PS/2 KVM 8 / 16-port USB KVM
<b>Cat5 KVM</b>	16 / 32-port IP Cat5 KVM 16 / 32-port two console Cat5 KVM 16 / 32-port high density Cat5 KVM
<b>KVM Extender</b>	IP KVM extender Cat5 PS/2 KVM Extender Cat5 USB KVM Extender
<b>Rackmount LCD Drawer</b>	1U 15" / 17" / 19" LCD drawer 2U 20" LCD drawer
<b>Rackmount LCD Display</b>	6U 15" / 7U 17" / 8U 19" LCD display 9U 20" LCD display

## Structure Diagram

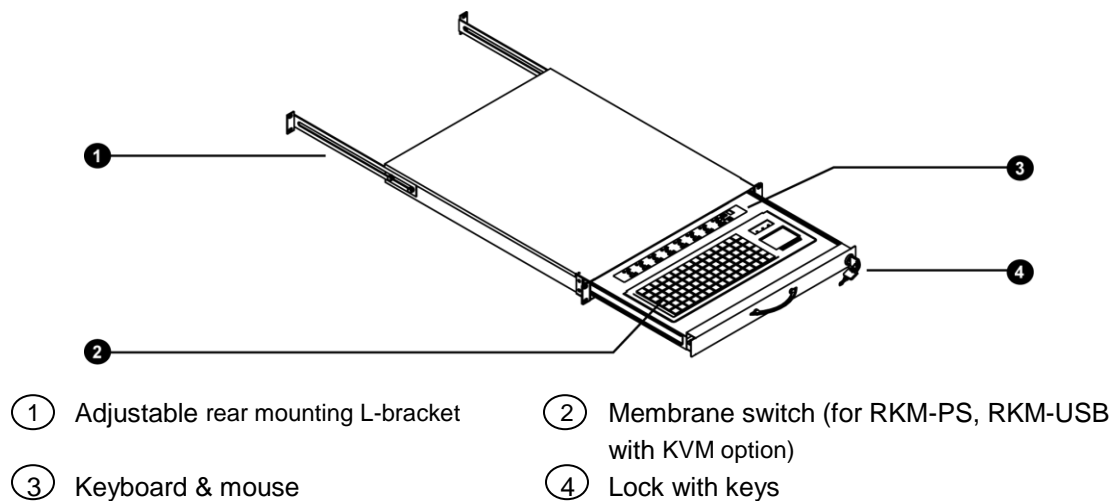

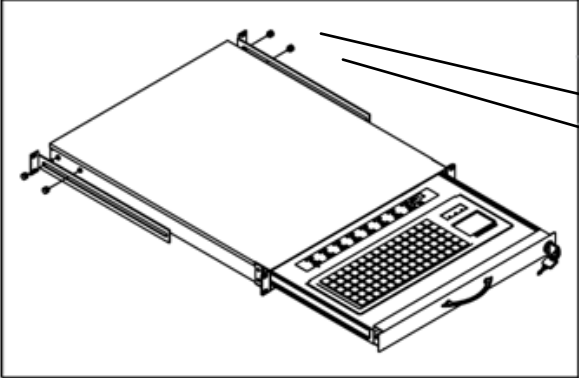
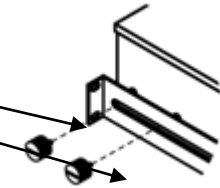
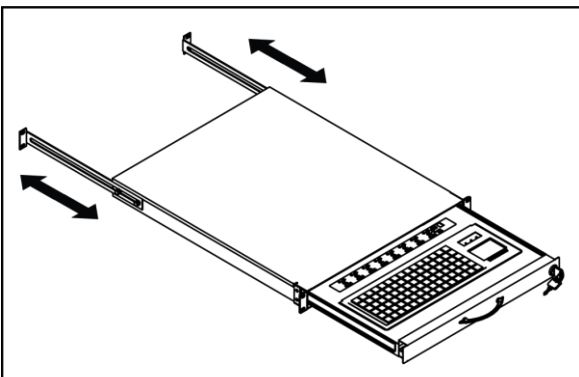
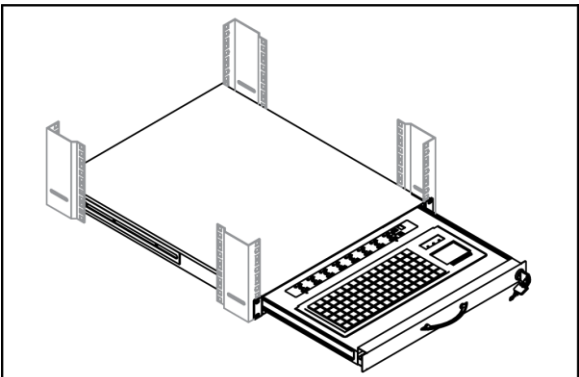

## Installation

 <p><b>Figure 1:</b> Installing the rear L-bracket to the LCD keyboard drawer.</p>	 <ul style="list-style-type: none"><li>• Install each rear L-bracket using two fasteners shown in <b>Figure 1</b>.</li><li>• Leave the fasteners slightly loose</li></ul>
 <p><b>Figure 2:</b> Aligning the rear L-brackets to a suitable length for the rack.</p>	<ul style="list-style-type: none"><li>• Measure the front and rear mounting depth of the rack.</li><li>• Align each rear L-bracket to a suitable length and tighten the fasteners shown in <b>Figure 2</b>.</li></ul>
 <p><b>Figure 3:</b> Fixing the LCD keyboard drawer into the rack.</p>	<ul style="list-style-type: none"><li>• Fix the LCD keyboard drawer into the rack.</li></ul> <p>* Hardware (screws and cage nuts) for fixing the mounting bracket to the rack is not provided.</p>

## Section 2: Keyboard & Mouse

Supporting layouts

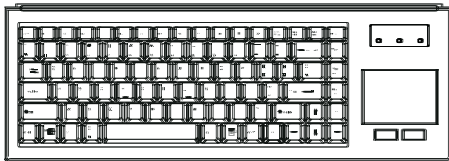

**e** Notebook type keyboard with touch-pad mouse

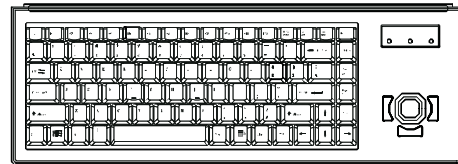

**b** Notebook type keyboard with trackball

Supporting layouts

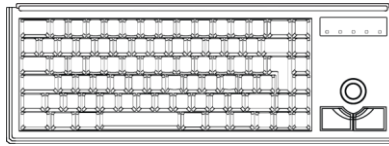

**c** Cherry keyboard with trackball

Supporting layouts

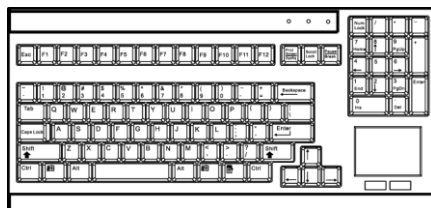

**t** Compact keyboard integrated with touch-pad mouse

Supporting layouts

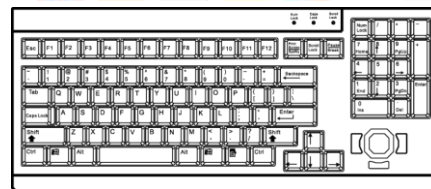

**d** Compact keyboard integrated with trackball

### Section 3: KVM Options for RKM-PS2 & RKM-USB

Our KVM is designed to seamlessly integrate into the rear of our full range of keyboard drawer solutions:

- For KVM operation, please refer to "KVM Switch" user manual
- Option with high density Cat5 KVM with either 16 or 32 ports
- Option with cost efficient DB-15 KVM integration with either 8 or 16 ports
- Please ask your supplier for full KVM details

### Section 4: Dimensions

Model	Product Dimension (W x D x H)	Packing Dimension (W x D x H)	Net Weight	Gross Weight
<b>RKM-PS2 &amp; RKM-USB Series (with KVM option)</b>	442 x 550 x 44.2 mm 17.4 x 21.6 x 1.74"	581 x 705 x 175 mm 22.9 x 27.8 x 6.9"	8 kg 18 lb	12 kg 26 lb
<b>RKM-PS2-SD &amp; RKM-USB-SD Series</b>	442 x 430 x 44 mm 17.4 x 14.6 x 1.73"	500 x 582 x 100 mm 19.7 x 22.9 x 3.9"	6 kg 13 lb	8 kg 18 lb





**Disclaimer**

While every precaution has been taken in the preparation of this document, Avenview Inc. assumes no liability with respect to the operation or use of Avenview hardware, software or other products and documentation described herein, for any act or omission of Avenview concerning such products or this documentation, for any interruption of service, loss or interruption of business, loss of anticipatory profits, or for punitive, incidental or consequential damages in connection with the furnishing, performance, or use of the Avenview hardware, software, or other products and documentation provided herein.

Avenview Inc. reserves the right to make changes without further notice to a product or system described herein to improve reliability, function or design. With respect to Avenview products which this document relates, Avenview disclaims all express or implied warranties regarding such products, including but not limited to, the implied warranties of merchantability, fitness for a particular purpose, and non-infringement.