



Control Your Video

VIDEO WALLS VIDEO PROCESSORS
VIDEO MATRIX SWITCHES
EXTENDERS SPLITTERS WIRELESS
CABLES & ACCESSORIES

PRODUCT MANUAL

Model: MLT-PROWALL-4K



Front

Back



Quad Multi-Input Videowall Controller with Audio Support and Rotation

Copyright

© 2016 Avenview Inc. All rights reserved.

The contents of this document are provided in connection with Avenview Inc. (“Avenview”) products. Avenview makes no representations or warranties with respect to the accuracy or completeness of the contents of this publication and reserves the right to make changes to specifications and product descriptions at any time without notice. No license, whether express, implied, or otherwise, to any intellectual property rights is granted by this publication. Except as set forth in Avenview Standard Terms and Conditions of Sale, Avenview assumes no liability whatsoever, and claims any express or implied warranty, relating to its products are strictly prohibited.



SECTION I: GETTING STARTED

I.1 IMPORTANT SAFEGUARDS

Please read all of these instructions carefully before you use the device. Save this manual for future reference.

What the warranty does not cover

- Any product, on which the serial number has been defaced, modified or removed.
- Damage, deterioration or malfunction resulting from:
 - Accident, misuse, neglect, fire, water, lightning, or other acts of nature, unauthorized product modification, or failure to follow instructions supplied with the product.
 - Repair or attempted repair by anyone not authorized by us.
 - Any damage of the product due to shipment.
 - Removal or installation of the product.
 - Causes external to the product, such as electric power fluctuation or failure.
 - Use of supplies or parts not meeting our specifications.
 - Normal wear and tear.
 - Any other causes which does not relate to a product defect.
- Removal, installation, and set-up service charges.

I.2 SAFETY INSTRUCTIONS





The **MLT-PROWALL-4K** 4 screen display videowall processor has been tested for conformance to safety regulations and requirements, and has been certified for international use. However, like all electronic equipments, the MLT-PROWALL-4K should be used with care. Read the following safety instructions to protect yourself from possible injury and to minimize the risk of damage to the unit.

- ⚠ Do not dismantle the housing or modify the module.
- ⚠ Dismantling the housing or modifying the module may result in electrical shock or burn.
- ⚠ Refer all servicing to qualified service personnel.
- ⚠ Do not attempt to service this product yourself as opening or removing housing may expose you to dangerous voltage or other hazards
- ⚠ Keep the module away from liquids.
- ⚠ Spillage into the housing may result in fire, electrical shock, or equipment damage. If an object or liquid falls or spills on to the housing, unplug the module immediately.
- ⚠ Have the module checked by a qualified service engineer before using it again.
- ⚠ Do not use liquid or aerosol cleaners to clean this unit. Always unplug the power to the device before cleaning.



Note: This equipment has been tested and found to comply with the limits for a Class A digital device, pursuant to part 15 of the FCC Rules. These limits are designed to provide reasonable protection against harmful interference when the equipment is operated in a commercial environment. This equipment generates, uses, and can radiate radio frequency energy and, if not installed and used in accordance with the instruction manual, may cause harmful interference to radio communications. Operation of this equipment in a residential area is likely to cause harmful interference in which case the user will be required to correct the interference at his own expense.

Properly shielded and grounded cables and connectors must be used in order to meet FCC emission limits. Avenview is not responsible for any radio or television interference caused by using other than recommended cables and connectors or by unauthorized changes or modifications to this equipment.

Warning symbols	Description
	<p>ONLY USE THE PROVIDED POWER CABLE OR POWER ADAPTER SUPPLIED. DO NOT TAMPER WITH THE ELECTRICAL PARTS. THIS MAY RESULT IN ELECTRICAL SHOCK OR BURN.</p>
	<p>THIS WARNING SYMBOL MEANS DANGER. WHEN THIS SYMBOL IS PLACED, YOU ARE IN AN ENVIROMENT THAT CAN CAUSE BODILY INJURY.</p>
	<p>DO NOT TAMPER WITH THE UNIT. DOING SO WILL VOID THE WARRANTY AND CONTINUED USE OF THE PRODUCT.</p>
	<p>THE VIDEO BOARDS ARE VERY SENSITIVE TO STATIC. PLEASE ENSURE IF RACK MOUNTED OR INSTALLED ON A SURFACE, IT SHOULD BE IN A GROUNDED ENVIRONMENT.</p>

	<p>⚠ WARNING</p> <p>Read & understand user guide before using this device.</p> <p>Failure to follow the proper installation instructions could result in damage to the product and preventing expected results.</p>
---	--



2.1 PACKAGE CONTENTS

Before you start the installation of the converter, please check the package contents.

1	MLT-PROWALL-4K	X 1	
2	IR REMOTE	X 1	
3	POWER SUPPLY (12V 3.33A) Either Standard US power connector or International power connector (UK,EU,AUS)* *Based on the order request.	X 1	
4	IR Extender	X 1	
5	C7 Power Cord	X 1	
6	User's Manual	X 1	

2.2 BEFORE INSTALLATION

- Put the product on an even and stable location. If the product falls down or drops, it may cause an injury or malfunction.
- Don't place the product in too high temperature (over 50°C), too low temperature (under 0°C) or high humidity.
- Use the DC power adapter with correct specifications and supplied with the unit. If improper power supply is used the unit may malfunction and cause a fire.
- Do not twist or pull by force ends of the video cable. It can cause malfunction.





To achieve best results with our MLT-PROWALL-4K we recommend a high quality 26 or 24 AWG HDMI cable with the below specifications to maintain signal integrity and distances.

Features

- Full UHD 4K/ 60 to 18Gbps High Speed at up to 48 Bit Deep Color
- UHD 4K/60 to 10.2 Gbps High Speed Deep Color up to 50ft (Active Series), 25ft Passive
- Full HD Up to 1080p/60 up to 75ft
- True Professional grade heavy-duty 24 or 26 gauge oxygen-free construction
- ProGrip connector utilizes up to 16 lbs of retention force to help keep connector in place
- SureLength length indicators on the connector heads make it easy to organize for installations
- Available in 7 colors for easy cable identification
- Up to 32 audio channels and 21:9 aspect ratio
- Simultaneous delivery of dual video and audio streams to multiple users
- Pro Grade Triple Shielding with 2x 100% coverage and 85% Premium Tinned Copper Braid construction
- Ethernet Capable
- 3D Ready
- Supports Deep Color and x.v. Color (Up to 48 Bit)
- 5.1/7.1 Lossless Dolby TrueHD and DTS-HD Surround Sound
- Audio Return Channel & Lip-sync
- ATC Certified
- 99.9% High Purity Copper Center Conductor
- Molded 24k Gold Plated HDMI male connectors on each end
- X-tra Flex CL3 rated jacket for easy installation
- RoHS Certified
- Lifetime Warranty



HDMI Premium Certified Cable label

This label ensures that the product was tested under the Premium HDMI Cable Certification Program

SECURE QR Code

Encrypted data in the QR code to identify the product with the Premium HDMI Cable app

SECURE fingerprint

Random elements in the hologram are recognized by the Premium HDMI Cable app, thus each label has its unique "fingerprint" and ensure the authenticity and quality of the product





IMPORTANT NOTES



1. Unpack MLT-PROWALL-4K and connected with 12V DC power supply unit.
2. Check User *Guide* from page 10 to 17 to select the display mode # as you need. Please pay attention to the Bezel Correction setting in page 10.
3. Set Display Mode dip SW based on the modes #. If the No. is 125, it means the dip SW pin 1, 2 & 5 should be set at ON (up) position. All the rest is still at OFF (down) position.
4. Install the LCD display and connect with MLT-PROWALL-4K as showed in UM with correct position, angle and direction.
5. Select input port and set EDID to get optimized input resolution. Please see more details in page 19 & 49.
6. Power on signal source, MLT-PROWALL-4K and LCD, then you will see the result.
7. **If no input signal, it will automatically power off after 60 seconds. Once the input signal appears again, the system will power on automatically.**
8. If you want to set bezel compensation, please see page 10.
9. If you want to add PIP or display dual contents on the video wall, please enable PIP/POP mode.
10. If any change is required in Dip SW, please turn system OFF & ON again to get new setting.
11. Please check output LED indicators and make sure all output LED is ON.
12. Please note that poor cable or long distance connection may cause dot noise.

MLT-PROWALL-4K Advanced applications *using* remote controller

1. If MLT-PROWALL-4K is installed at a location that can't be directly accessed by remote control, please connect IR Extender and set IR receiver at a position that can be accessed by IR remote control.
2. **Turn all Dip SW pins in [Main Input] to OFF position to switch the authority of the system control to OSD setting. If any [Main Input] Dip SW is turned to ON position, MLT-PROWALL will follow the command from Dip SW settings but not the settings from OSD menu.**
3. **If no input signal, the system will automatically power off after 60 seconds. You can set [Standby Time Out] to "0" to keep MLT-PROWALL-4K in power on status even no input signal. Once you had selected an input port and input signal has been detected, MLT-PROWALL-4K will wake up and send out the signal to LCD automatically.**
4. Before you select specific display mode from OSD menu, please check Display Mode list. You also need to familiar with OSD operation. After selecting display mode, the OSD will be also split into different sections.
5. Open OSD and navigate to [Video Wall] menu. You will find the icons for all display modes with the display mode number at the bottom position. Please click on it to select the display mode you need.
6. **For cascade and advanced operations, please see more details in User Manual. When you operate [Video Wall] menu, it may have frame tear in the display. It will disappear after you power OFF/On the system.**
7. After finishing OSD operation, please save the result in [Profile] menu. When you turn OFF/ON the system again, it will remain the same setting without change.
8. If any of the [Main Input] Dip SW has been turned to ON position, the system will take Dip SW setting as first priority and user needs to load [Profile] settings to show the setting from OSD menu operations.



Table of Contents

1	Introduction.....	1
2	Features	1
3	Tips for installation and operation.....	2
4	Panel Description and key functions.....	2
5	Preset display modes.....	3
5.1	LCD (TV) selection.....	3
5.2	Bezel compensation.....	3
5.3	PIP/POP settings.....	4
5.4	Preset display mode list.....	5
5.5	How to set DIP SWITCH.....	11
5.6	Signal source output resolution selection.....	12
6	MLT-PROWALL-4K Application case study.....	13
6.1	Preset mode: Mode 145.....	13
6.2	Preset mode: Mode 00.....	13
6.3	Preset mode: Mode 01.....	14
6.4	Preset mode: Mode 03.....	14
7	Multiple MLT-PROWALL-4K cascade.....	15
7.1	Setup procedures.....	15
7.2	Signal source resolution selection.....	15
7.3	Case study a: 4k/2k 4x4 video wall.....	15
7.4	Case study B: 4k/2k 3x3 video wall.....	16
7.5	Case study C: 4k/2k 8x TV irregular video wall.....	16
8	Multiple contents in cascaded display.....	17
9	Examples for cascaded display.....	18
10	OSD menu and functions.....	28
10.1	[Picture] color adjustment.....	29
10.2	[Image Setup] for PC graphics VGA input.....	29
10.3	[Image Properties].....	29
10.3.1	Color.....	30
10.3.2	Scaling.....	30
10.3.3	PIP/POP settings.....	30
10.3.4	Image Orientation.....	32
10.4	Video wall setting.....	33
10.4.1	Output Mode.....	33
10.4.2	Zoom.....	34
10.4.3	Pan.....	35
10.4.4	Overlap.....	35
10.4.5	Example for two MLT-PROWALL-4K Cascade.....	35
10.5	[Options]: OSD Miscellaneous Functions.....	36

10.5.1	[Information]: System Information.....	36
10.5.2	[Language]: OSD language.....	36
10.5.3	[Reset].....	37
10.5.4	[Accessibility].....	37
10.5.4.1	[Menu Time Out].....	37
10.5.4.2	[Logo Time out].....	38
10.5.4.3	[Standby Time Out].....	38
10.5.5	[Setting].....	38
10.5.5.1	Audio [Mute].....	38
10.5.5.2	Frame Lock and Free Run mode.....	39
10.5.5.3	[Box ID].....	39
10.5.5.4	[Profile] setting.....	39
10.5.5.5	[Network].....	40
10.5.5.5.1	RS232 setting.....	41
10.5.5.5.2	Example of low cost RS232 controller.....	42
10.5.5.6	[EDID] setting—Signal source output resolution setting.....	42

INTRODUCTION

MLT-PROWALL-4K is four channel high end 10-bit processor with 3D motion adaptive de-interlace, low angle smooth algorithm and 3:2/2:2 film mode processing for creative irregular video wall processing.

It is a new concept video wall controller designed with 3 input & 4 output ports and with the capability for max. up to 256 pre-defined display modes, targeting at the market with the requirement for irregular creative video wall. All the setting can be achieved through Dip switch settings on MLT-PROWALL-4K. Pre-defined display modes include different rotation angle, position and array. Customized display mode is possible to add in. PIP/POP function is embedded in MLT-PROWALL-4K. Dual contents can be displayed on the video wall at the same time. One HDMI 4k/2k loop out port is convenient for daisy chain connection while cascading with multiple units of MLT-PROWALL-4K for video wall larger than 4 LCD.

MLT-PROWALL-4K is designed with 3-4 TV as one display unit based on full HD panel with the same size and resolution. If user wants to display with different LCD size, bezel dimension and resolution, then MLT-PROWALL-4K will be another solution. Advanced applications can be implemented in MLT-PROWALL-4K through the use of OSD and remote controller.

1. To cascade multiple MLT-PROWALL-4K for bigger display.
2. To share 4k UHD content with multiple MLT-PROWALL-4K to display high resolution 4K video wall.
3. Able to execute image flip/rotation at 90/180/270 degrees. Image flip/rotation will be applied to all 4 output ports. User can use this function to create more fancy applications in pre-defined display modes.
4. More flexible PIP/POP settings with flexible size, position and aspect ratio selection.
5. User can set up to 5 different display profiles in MLT-PROWALL-4K and recall it through IR remote or RS232. It includes different input sources, PIP/POP setting, image flip and rotation.
6. While multiple MLT-PROWALL-4K cascade, user can set all MLT-PROWALL-4K combined into one big display with single content or multiple contents in one video wall through remote controller or RS232.

FEATURES

- Four Output Video Wall Controller;
- 1080P output resolution on each port;
- Supports 4K/2K Input resolution with no compression;
- 10 bits 4:4:4 full bandwidth sampling with 3D de-interlace;
- Pre-defined display profiles;
- Selectable preset bezel correction;
- PIP/POP function;
- Front panel DIP Switch selections, no PC required;
- Controlled through RS 232 or IR remote;
- HDMI Loop out port for daisy chain connection;
- Cascade with multiple MLT-PROWALL-4K for expansion;
- Supports display flipping and rotation;
- Bezel Compensation;
- 256 Preset Layouts



3 Tips for installation and operation

- 3.1 If multiple MLT-PROWALL-4K cascade function is executed, user can put MLT-PROWALL-4K in front of the video wall to do the setting, then install to the final place. User can also extend IR receiver to a location in front of video wall for further settings.
- 3.2 Each MLT-PROWALL-4K is equipped with IR extenders. User can extend the cable distance up to 20m through audio cable or connected with Cat 5/6 UTP cable.
- 3.3 OSD Lock / Unlock: When continuously press [MENU] key in IR Remote Controller for 5 seconds, the OSD function will be locked to prevent from the changes of the settings. To press MENU key for 5 seconds again, it will unlock OSD and user can manipulate the OSD again.
- 3.4 Picture menu in the OSD can only be activated while the input signal is not in color [Preset Mode]. To select [Image Properties] [Custom] [Save], then user can activate [Picture] menu again.
- 3.5 [Image Setup] menu will not be activated if the input source is not from VGA.
- 3.6 Once finishing one video wall setting, user can apply the same setting value to next project with the same configuration. It will save time for the installation and settings.
- 3.7 Please make sure the position of the LCD should match the output ports in MLT-PROWALL-4K, 3.8 MLT-PROWALL-4K can only be connected with the same size and resolution 16:9 LCD to keep correct position, otherwise, customization is required for different size and aspect ratio LCD.
- 3.9 A poor signal cable connection may cause some noise on the display. Unplug the cable and connect it again may solve the problem.
- 3.10 If the video wall aspect ratio is not the same as signal source, it may create abnormal aspect ratio in the image. Users can select EDID in MLT-PROWALL-4K to let PC output a desired resolution. To apply different [Overlap] value under [Video wall] menu can also change the aspect ratio issue.

4 Panel Description and key functions

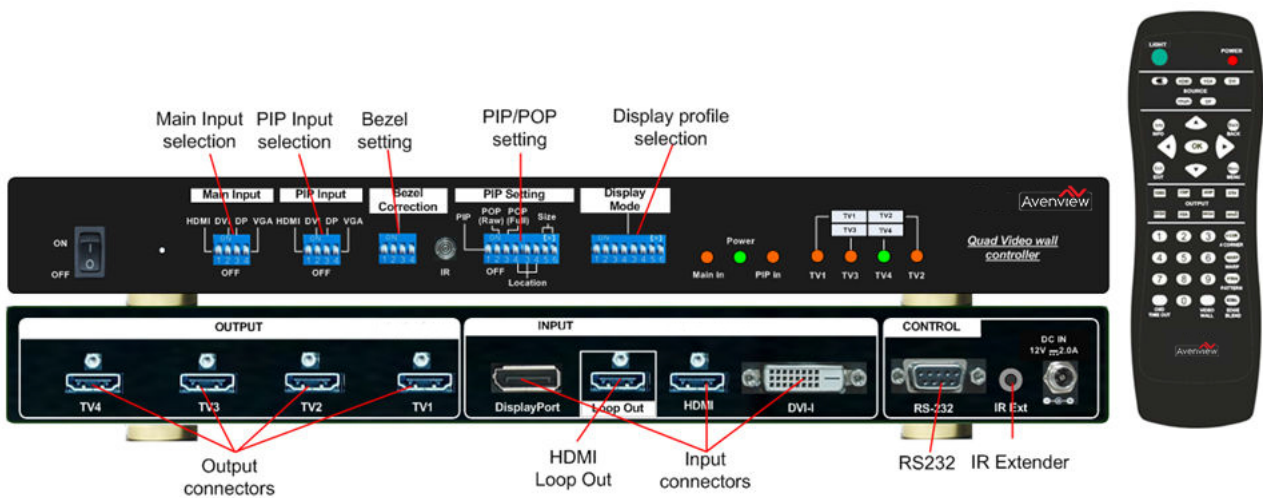

Note: After finishing DIP SW setting, Power OFF and ON again is required to execute the settings.



5 Preset Display modes

5.1 LCD (TV) selection

- Type of LCD: low cost LCD or TV can be used. No need to have matrix feature in the display panel.
- Some Display Modes support TV at top down flip position to compensate the bezel size difference in TV.
- Aspect ratio: based on 16:9 aspect ratio LCD (TV).
- Output resolution: the default output resolution is 1920x1080 @60Hz.
- All the LCD (TV) can support 1920x1080 input timing with 16:9 aspect ratio can be used, including 1920x1080, 1600x900 and 1366x768 resolution.
- Customization is required if user uses LCD with different dimension and bezel size.

5.2 Bezel compensation

Bezel compensation function is built-in in MLT-PROWALL-4K. It is based on LG 47", 55" LCD and 1.5% for conventional TV. **User needs to check if [Bezel] dip SW shall be ON or OFF based on the mode list in page 12-18. The actual active display dimensions in different brand name with the same LCD nominated size may be still different.**

Bezel correction modes	Horizontal correction	Vertical correction	Estimated "Active to Active" bezel correction value (mm) in H&V							
			32" LCD	40" LCD	42" LCD	47" LCD	50" LCD	55" LCD	60" LCD	65" LCD
3.5mm	0.289280%	0.514177%	2.35	2.86	2.99	3.31	3.50	3.81	4.14	4.46
4.9mm	0.471163%	0.837464%	3.64	4.47	4.68	5.20	5.51	6.03	6.56	7.08
1.50%	1.496090%	2.552533%	10.68	13.28	13.93	15.55	16.52	18.14	19.77	21.39

55LV77A / 55LV75A



Active to Active (Gap=0.3mm) **3.8mm**
 Bezel to Bezel **3.5mm**
 2.25mm(Left/Top) / 1.25mm(Right/Bottom)

Bezel correction with 3.5mm and 4.9mm will apply to all edges in the whole display. 1.5% bezel correction will only apply to the edges adjacent with other TV. In below video wall, TV3 bezel correction only applies to edge A & B but not in edge C&D

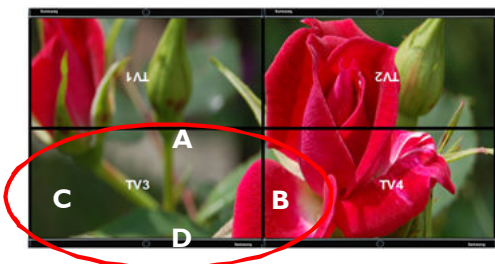

There are 4 type of bezel compensation in display mode list. Below % is calculated by total bezel size divided by active display area in H&V:

- No bezel correction: no information missing
- 3.5mm mode: $H = 0.289280\%$, $V = 0.514177\%$
- 4.9mm mode: $H = 0.471163\%$, $V = 0.837464\%$
- 1.5% mode: $H = 1.496090\%$, $V = 2.552533\%$

The actual "bezel to bezel" size to be corrected is based on the active display width (H) and height (V) multiple the above % value.

For example, if user uses 55" panel (1218 * 685mm active display) and select 4.9mm bezel correction mode, the "Bezel to Bezel" value will be

$$H = 1218 * 0.471163\% = 5.74\text{mm}$$

$$V = 685 * 0.837464\% = 5.74\text{mm}$$

The actual "Active to Active" size is

$$H = 5.74\text{ mm} + 0.3\text{mm} = 6.04\text{mm}$$

$$V = 5.74\text{ mm} + 0.3\text{mm} = 6.04\text{mm}$$



5.3 PIP/POP setting

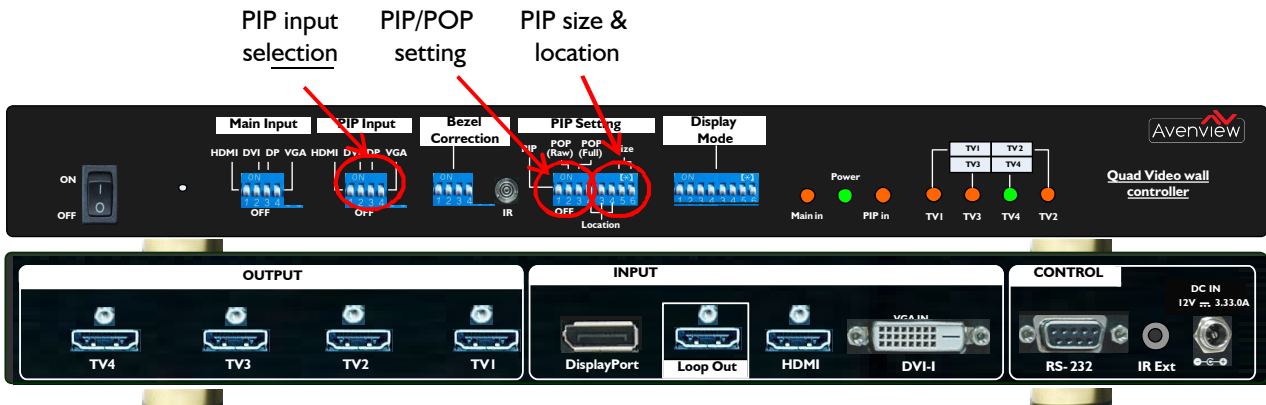

a. PIP Input selection

User can use Dip SW to select PIP/POP input source from HDMI, DVI, DP & VGA input ports.

b. PIP/POP mode selection: direct selection from [PIP Mode] DIP SW

PIP (Picture in Picture) mode

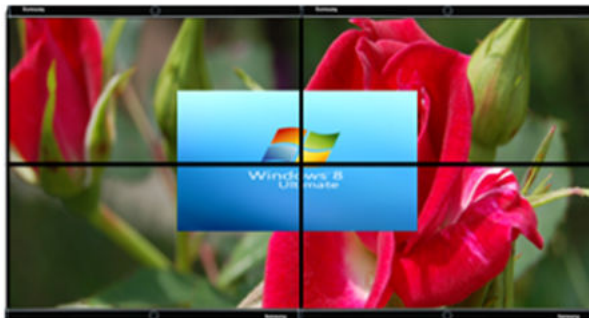

“POP Raw” display mode



“POP Full” display mode



Please adjust the aspect ratio of POP image under [Image Properties] menu while using remote controller.

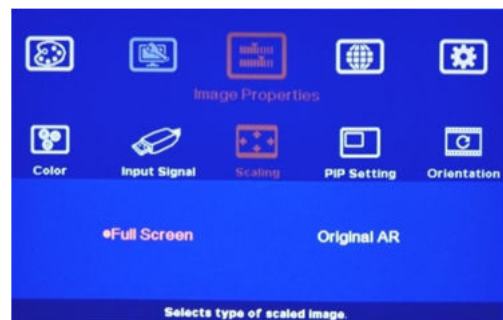

c. PIP Size and Location

Preset size: Max 1024x768 resolution (100%)

Preset selection from DIP SW: 25%, 50%, 75%, 100%

Preset Location: 7 positions across the video wall can be selected from DIP SW. The positions are as follows: Top Left (3), Top Right (34), Bottom Left (5), Bottom Right (4), Center up (35), Center (00), Center Down (45)

Note: *1. After DIP SW selection, user needs to Power OFF/ON again to implement the settings.

***2. User can continuously adjust PIP size and location via remote controller.**



5.4 Preset display mode list

Please select 1080p as input source for single MLT-PROWALL-4K application to get the best video quality.
[Bezel on] means to set Dip SW [Bezel] pin at ON

[UP] position.

Mode 00 - Duplicate Mode



4 displays show the same full screen content as video source.

Mode 01 – 2x2 (Ratio 16:9)



Bezel off: no correction
Bezel on: 3.5mm bezel to bezel

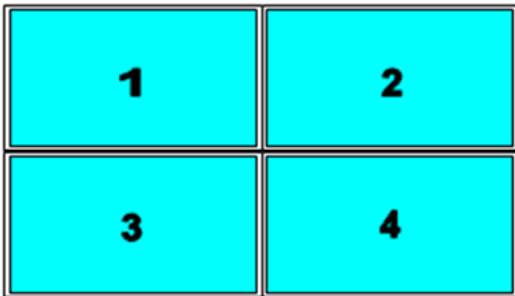

Mode 02 – 2x2 (Ratio 16:9)



Bezel off: 4.9mm bezel to bezel
Bezel on: 1.5% bezel correction

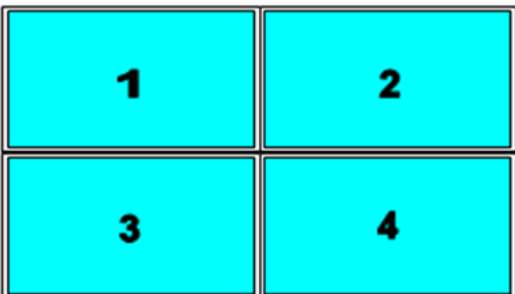

Mode 03 – 2x2 with top TV upside down (Ratio 16:9)



Bezel off: no bezel correction
Bezel on: 1.5% bezel correction

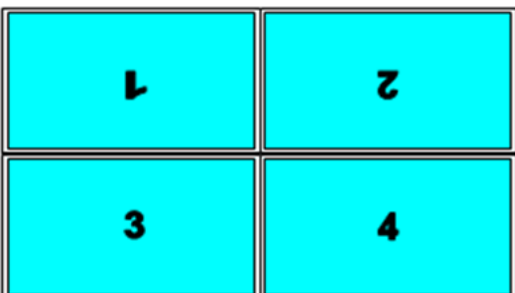

Mode 04– 4x1 (Ratio 2.25)



Bezel off: no correction
Bezel on: 3.5mm bezel to bezel

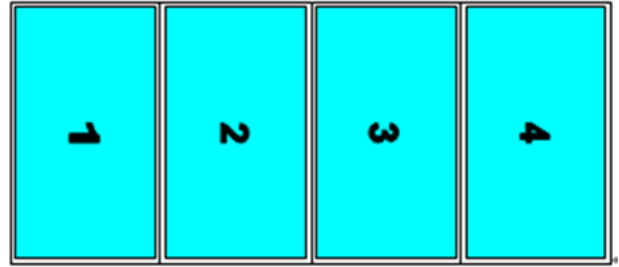

Mode 04A – 1x4



Bezel off: no correction
Bezel on: 3.5mm bezel to bezel



Please apply portrait signal source to get normal viewing angle. The aspect ratio of the content needs to match the display

Mode 05 –4x1 (Ratio 2.25)



Bezel off: 4.9mm bezel to bezel
Bezel on: 1.5% bezel correction

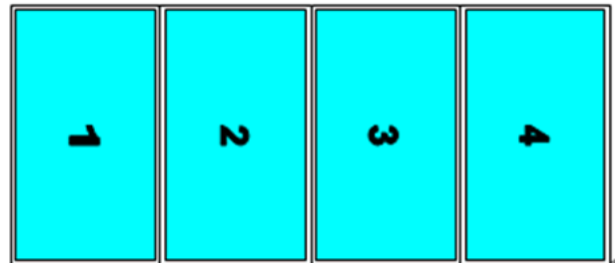

Mode 05A –4x1 (Ratio 2.25)



Bezel off: 4.9mm bezel to bezel
Bezel on: 1.5% bezel correction



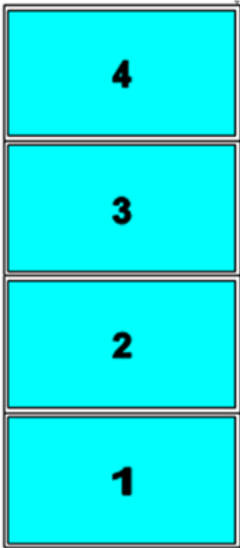

Please apply portrait signal source to get normal viewing angle. The aspect ratio of the content needs to match the display

Mode 06 – 3x1 (Ratio 1.69)

(#4 output will show full screen image)



Bezel off: no correction
Bezel on: 3.5mm bezel to bezel

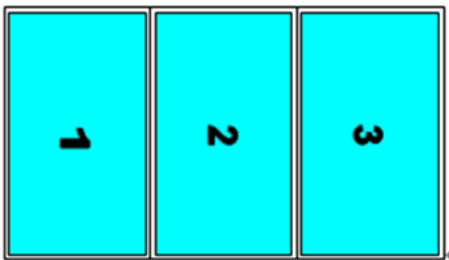

Mode 06A – 1x3 (Ratio 1.69)



Bezel off: no correction
Bezel on: 3.5mm bezel to bezel

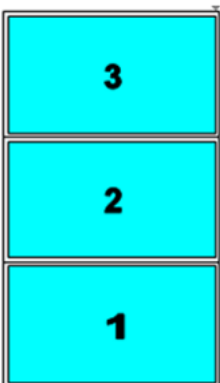

Please apply portrait signal source to get normal viewing angle. The aspect ratio of the content needs to match the display

Mode 12 –3x1 (Ratio 1.69)

(#4 output will show full screen image)



Bezel off: 4.9mm bezel to bezel
Bezel on: 1.5% bezel correction

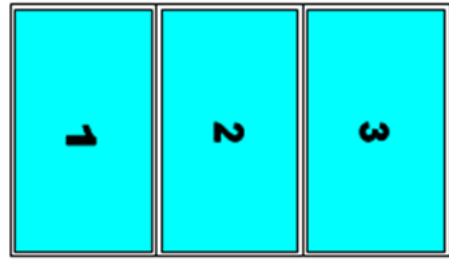

*** Mode 12A –1x3 (Ratio 1.69)**



Bezel off: 4.9mm bezel to bezel
Bezel on: 1.5% bezel correction



Please apply portrait signal source to get normal viewing angle. The aspect ratio of the content needs to match the display

Mode 13 – 2x2 with clockwise 15rotation (Ratio

1.7)



Bezel off: no correction
Bezel on: 3.5mm bezel to bezel

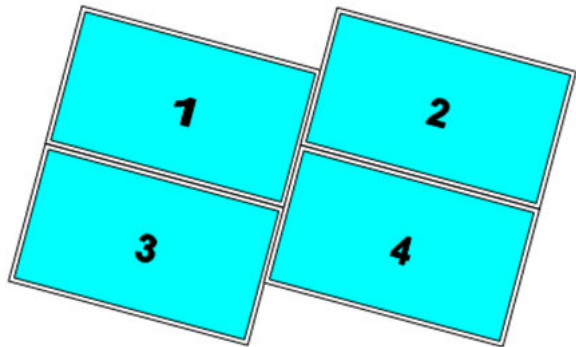

Mode 14 – 2x2 with clockwise 15rotation (Ratio

1.7)



Bezel off: 4.9mm bezel to bezel
Bezel on: 1.5% bezel correction



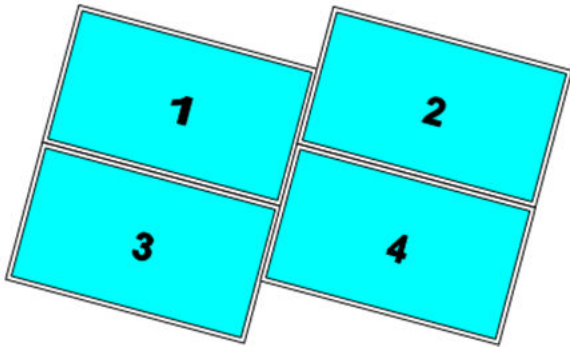

Mode 15 – 2x2 with clockwise 15rotation and TV1 & TV2 at upside down position (Ratio 1.7)



Bezel off: no correction
Bezel on: 1.5% bezel correction

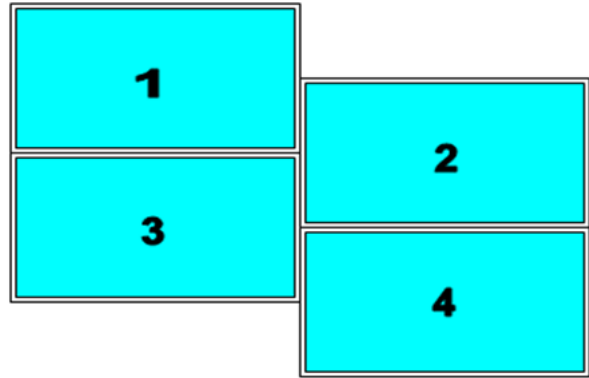

Mode 24 – 2x2 with TV3 & TV4 Right shift 1/2 panel width (Ratio 2.22)



Bezel off: no correction
Bezel on: 3.5mm bezel to bezel

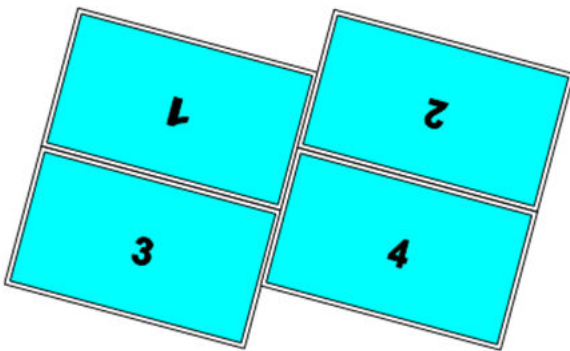

Mode 16– 2x2 with TV2 & TV4 shift down 1/2 panel height (Ratio 1.42)



Bezel off: no correction
Bezel on: 3.5mm bezel to bezel

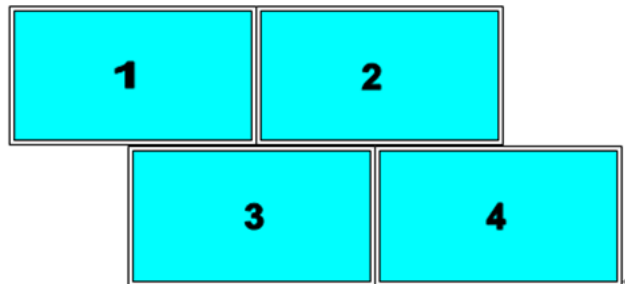

Mode 25 – 2x2 with TV3 & TV4 Right shift 1/2 panel width (Ratio 2.22)



Bezel off: 4.9mm bezel to bezel
Bezel on: 1.5% bezel correction

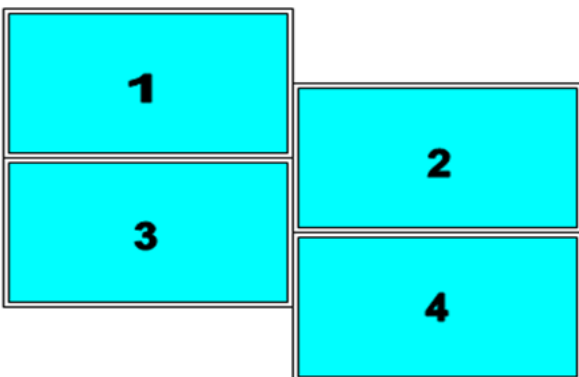

Mode 23– 2x2 with TV2 & TV4 shift down 1/2 panel height (Ratio 1.42)



Bezel off: 4.9mm bezel to bezel
Bezel on: 1.5% bezel correction

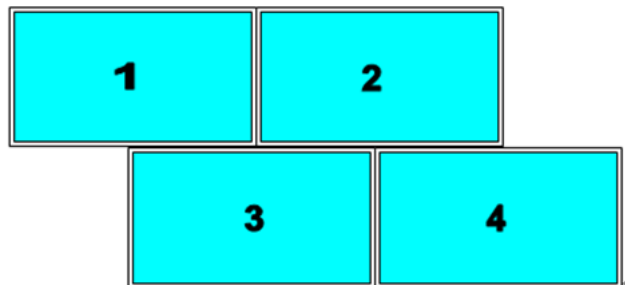

Mode 26 – (Ratio 1.89)



Bezel off: no correction
Bezel on: 3.5mm bezel to bezel

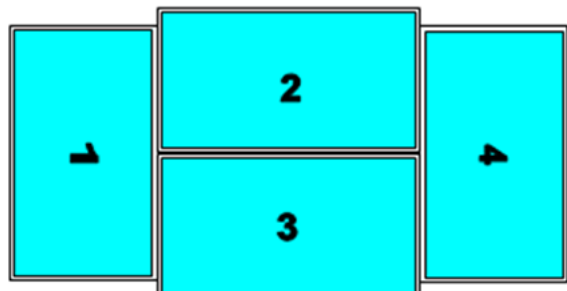

Mode 34 – (Ratio 1.89)



Bezel off: 4.9mm bezel to bezel
 Bezel on: 1.5% bezel correction

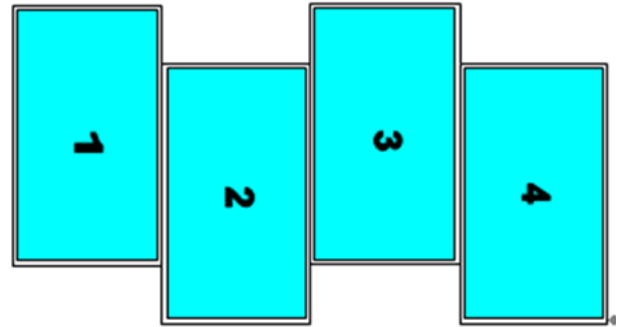
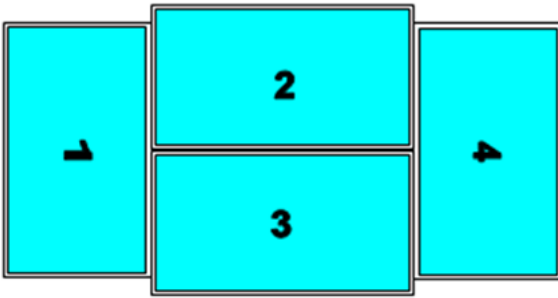

Mode 35 – (Ratio 5.33) for 3x3 application



Bezel off: no correction
 Bezel on: 3.5mm bezel to bezel



Mode 56 – TV4 Down shift 1/4 panel height (Ratio 1.8)



Bezel off: no correction
 Bezel on: 3.5mm bezel to bezel

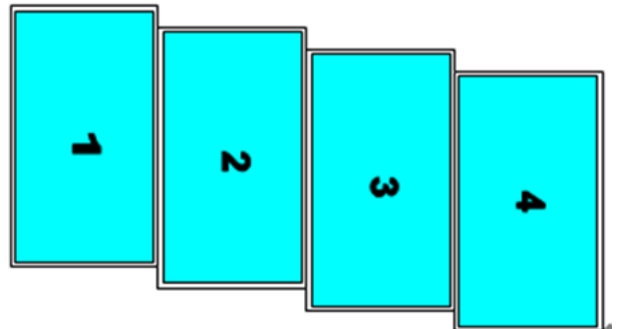

Mode 36 – (Ratio 5.33) for 3x3 application



Bezel off: 4.9mm bezel to bezel
 Bezel on: 1.5% bezel correction



Mode 123 – TV4 down shift with 1/4 panel height (Ratio 1.8)



Bezel off: 4.9mm bezel to bezel
 Bezel on: 1.5% bezel correction

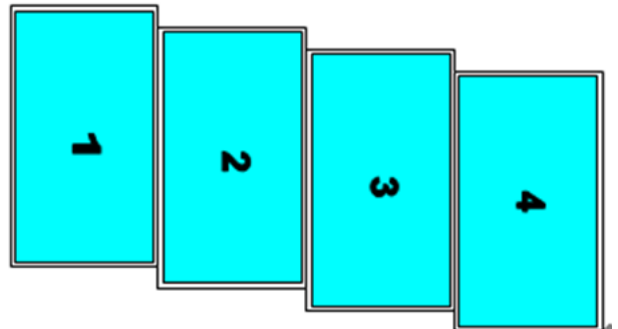

Mode 45 –TV2 & TV4 Down shift with 1/4 panel height (Ratio 1.8)



Bezel off: no correction
 Bezel on: 3.5mm bezel to bezel

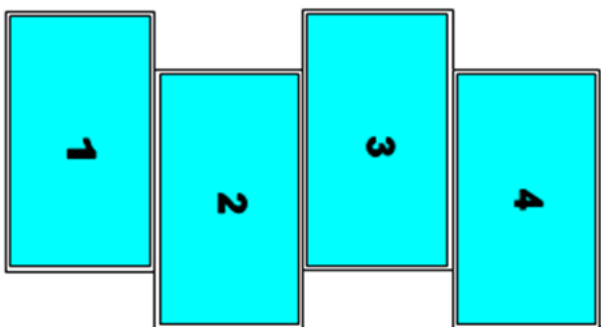

Mode 124 – 75counterclockwise rotation(Ratio 1.77) (#4 output will show full screen image)



Bezel off: no correction
 Bezel on: 3.5mm bezel to bezel

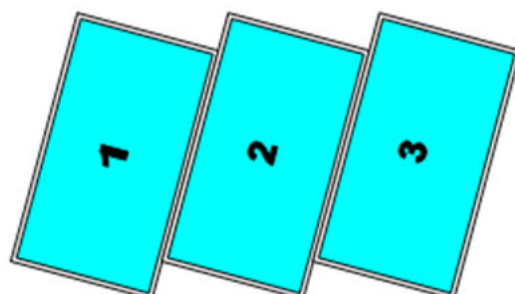

Mode 46 – TV2 & TV4 Down shift with 1/4 panel height (Ratio 1.8)



Bezel off: 4.9mm bezel to bezel
 Bezel on: 1.5% bezel correction



Mode 125 – 75counterclockwise rotation(Ratio

1.77) (#4 output will show full screen image)



Bezel off: 4.9mm bezel to bezel
Bezel on: 1.5% bezel correction

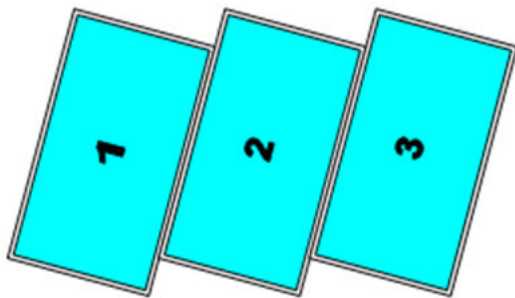

Mode 126 – 48.37counterclockwise rotation

(Ratio 1.03)



Bezel off: no correction
Bezel on: 3.5mm bezel to bezel

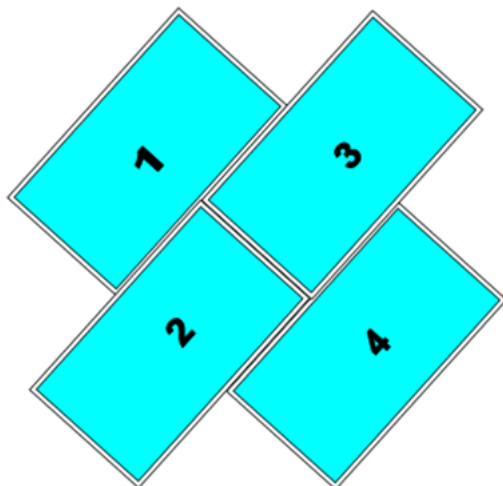

Mode 134 – 48.37counterclockwise rotation

(Ratio 1.03)



Bezel off: 4.9mm bezel to bezel
Bezel on: 1.5% bezel correction

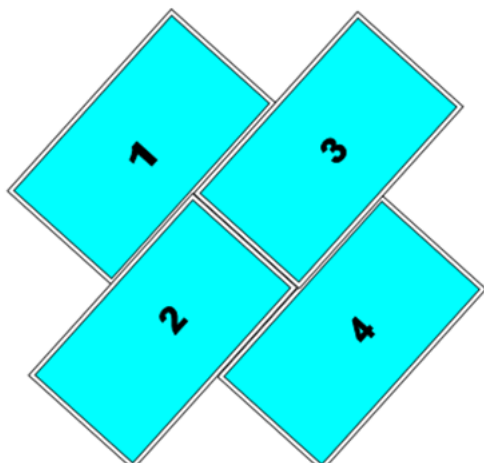

Mode 135 – 45clockwise rotation (Ratio 1.33)



Bezel off: no correction
Bezel on: 3.5mm bezel to bezel

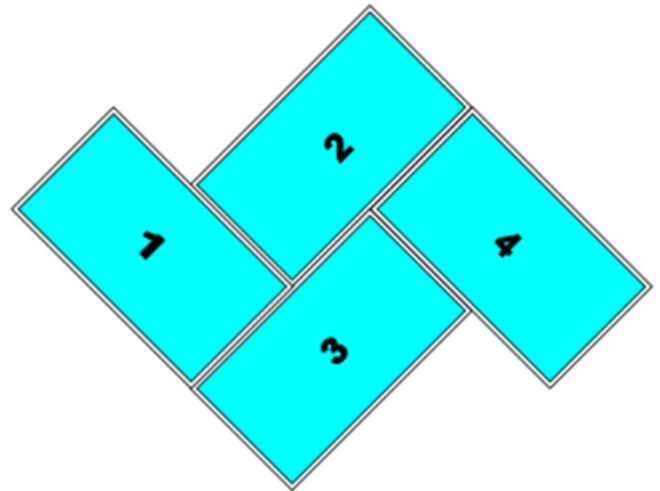

Mode 136 – 45 clockwise rotation (Ratio 1.33)



Bezel off: 4.9mm bezel to bezel
Bezel on: 1.5% bezel correction

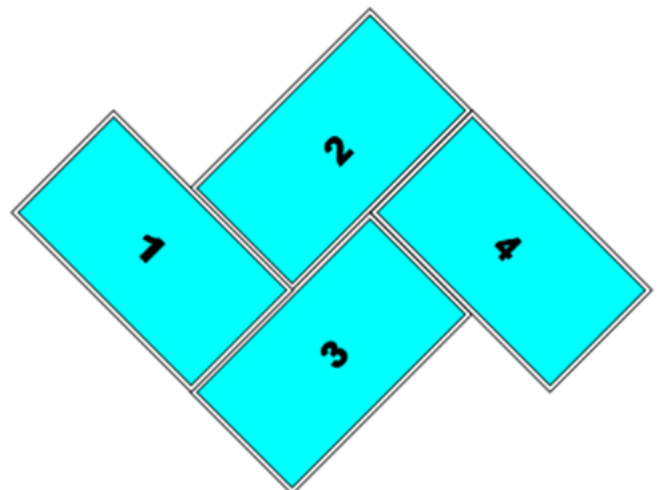

Mode 145 – (Ratio 1)



Bezel off: no correction
Bezel on: 3.5mm bezel to bezel

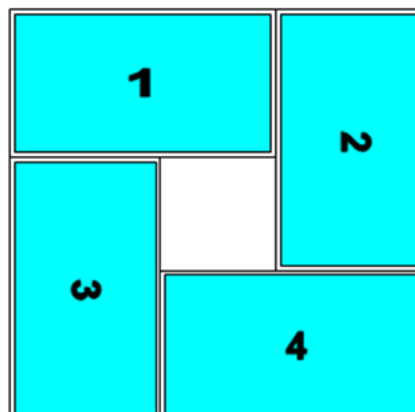

Mode 146 – (Ratio 1)



Bezel off: 4.9mm bezel to bezel
Bezel on: 1.5% bezel correction

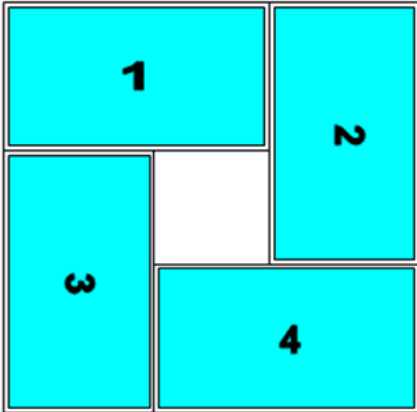

Mode 156 (Ratio 1)



Bezel off: no correction
Bezel on: 3.5mm bezel to bezel

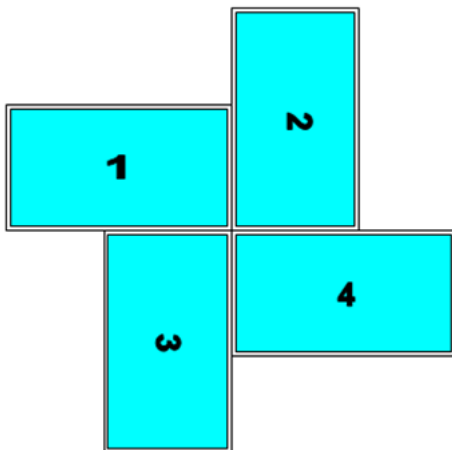

Mode 234 (Ratio 1)



Bezel off: 4.9mm bezel to bezel
Bezel on: 1.5% bezel correction

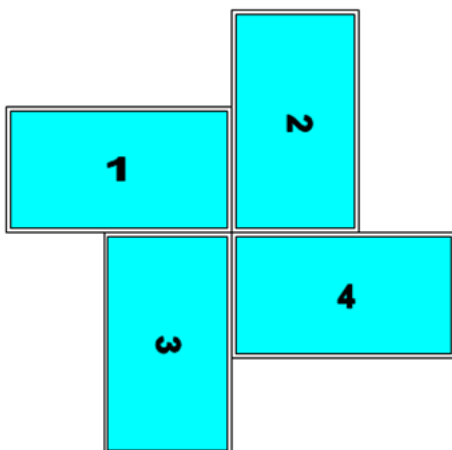

Example for customized display modes

Display modes can be customized based on user's requirements under some purchase lot. Below are examples for customized modes.

* Mode 145/146 Rotated 45

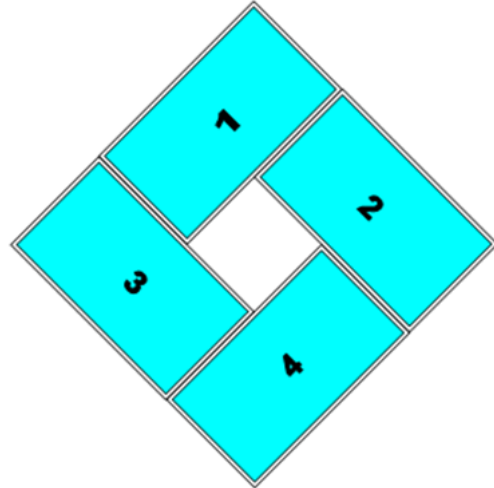

* Mode 156/234 rotated 45

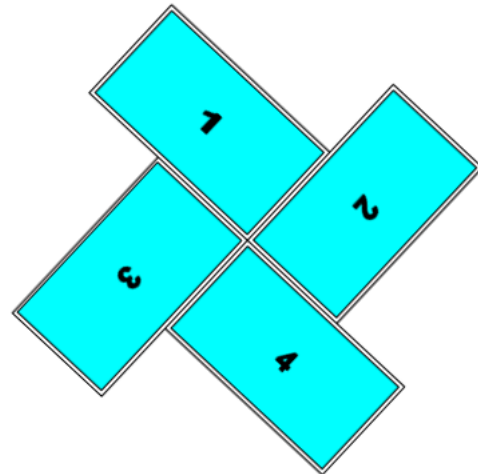

5.5 How to set DIP SWITCH

5.5.1 Example one

* Mode 145 as example:

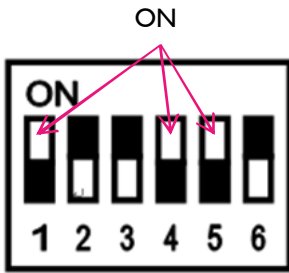

1. Mode 145 means DIP SW pin #1, #4 & #5 shall be set to "ON" (UP) position.

2. MLT-PROWALL-4K output connection

- □ MLT-PROWALL-4K TV1 output is connected to #1 LCD
- □ MLT-PROWALL-4K TV2 output is connected to #2 LCD MLT-PROWALL-4K TV3 output is connected to #3 LCD MLT-PROWALL-4K TV4 output is connected to #4 LCD

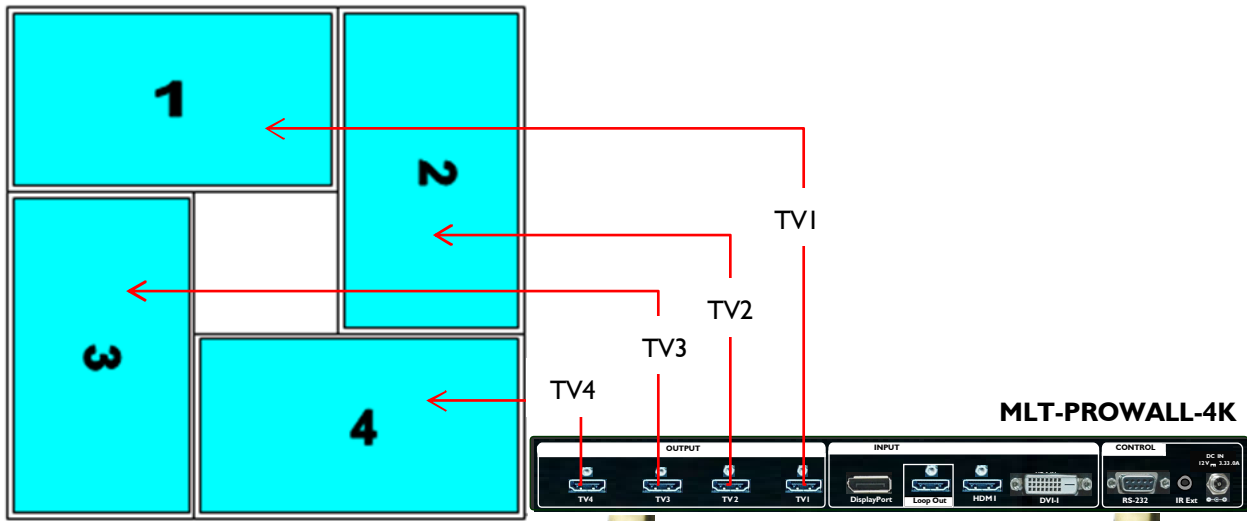

5.5.2 Example two

* Mode 124 — 75counterclockwise rotation(Ratio 1.77) (#4 output will show full screen image)

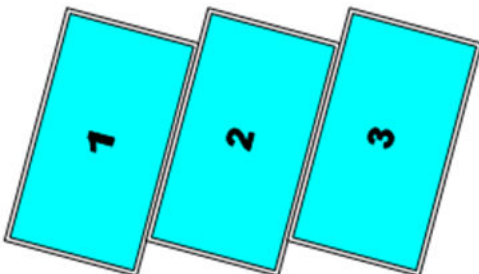
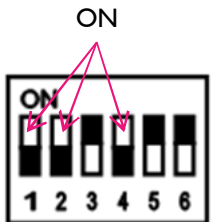

Mode 124 means DIP SW pin #1, #2 & #4 shall be set to "ON" (UP) position.

MLT-PROWALL-4K output connection

- 1.1 MLT-PROWALL-4K TV1 output is connected to #1 LCD
- 1.2 MLT-PROWALL-4K TV2 output is connected to #2 LCD
- 1.3 MLT-PROWALL-4K TV3 output is connected to #3 LCD
- 1.4 MLT-PROWALL-4K TV4 output will show full screen content same as signal source.



5.5.3 Example three

* Mode 06A – 1x3 (Ratio 1.69)

(Please apply portrait image content to get normal viewing angle. If the content is not at portrait position, then user needs to use MLT-PROWALL-4K to rotate the content.)



Mode 06A means DIP SW pin #6 shall be set to “ON” position.

“A” means this mode is only be achieved by rotating the image from signal source. If the image is not rotated from signal source, then it is necessary to rotate the image by MLT-PROWALL-4K through IR remote controller. Please pay attention to content aspect ratio.

MLT-PROWALL-4K output connection

I.1 MLT-PROWALL-4K TV1 output is connected to #1 LCD

I.2 MLT-PROWALL-4K TV2 output is connected to #2 LCD

I.3 MLT-PROWALL-4K TV3 output is connected to #3 LCD

I.4 MLT-PROWALL-4K TV4 will show full screen image same as signal source. It can be connected to other LCD or monitor for system monitoring.

5.6 Signal source output resolution selection

Video signal resolution setting will affect final video quality. Please follow below recommendation to set signal source output resolution.

5.6.1 Basic concept for video source output resolution settings

- d. Horizontal direction: If only single unit is required in horizontal direction, please set the horizontal output resolution at 1920. If multiple units of MLT-PROWALL-4K are required in horizontal cascade direction, then please set the horizontal output resolution at 3840.
- e. Vertical direction: If only single unit is required in vertical direction, please set the vertical output resolution at 1080. If multiple units of MLT-PROWALL-4K are required in vertical cascade direction, please set the vertical output resolution at 2160.

5.6.2 Example for input resolution settings:

- a. When using single MLT-PROWALL-4K, please apply 1920x1080 @60Hz input resolution.
- b. For dual MLT-PROWALL-4K horizontal cascade, please set 3840x1080 @60Hz as input resolution.
- c. For dual MLT-PROWALL-4K vertical cascade, please set 1920x2160 @60Hz as input resolution
- d. For 2x2 four MLT-PROWALL-4K cascades, 3840x2160 @30Hz input resolution will get the best video quality.
- e. For more complicated cascade, please follow the instruction in section 9.

5.6.3 How to set input timing resolution:

- a. Please change the input resolution by [EDID] setting in page 49 or to change output resolution and select correct aspect/scaling setting in PC output resolution setting.
- b. If the output resolution is not standard VESA standard timing, user needs to set the output resolution from display card custom output timing setting.

5.6.4 Please confirm the setting result by [INFO] menu from IR remote controller.



6 MLT-PROWALL-4K Application case study

6.1 Preset mode: Mode 145



1. DIP SW #1, #4 & #5 pins in [Display Mode] are set at "ON" (UP) position.
2. Connect MLT-PROWALL-4K outputs to related LCD
 - a. TV1 to #1 LCD
 - b. TV2 to #2 LCD
 - c. TV3 to #3 LCD
 - d. TV4 to #4 LCD
3. To check if Bezel compensation is required or not. If yes, please enable "F2" bezel compensation DIP SW.
4. If PIP is required, set DIP SW in [PIP Input],[PIP Mode], and [PIP Size & Location].

After finishing DIP SW setting, Power OFF and ON again is required to execute the command in DIP SW setting in MLT-PROWALL-4K.

6.2 Preset mode: Mode 00



All DIP SW pins in [Display Mode] are set at "OFF" position.

All outputs will have the same contents as input source. It becomes 3x in / 4x out video converter and switcher.

If PIP is required, please set DIP SW in [PIP Input], [PIP Mode], and [PIP Size & Location].



6.3 Preset mode: Mode 01

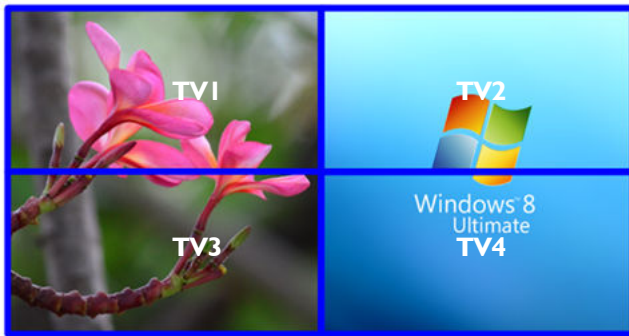
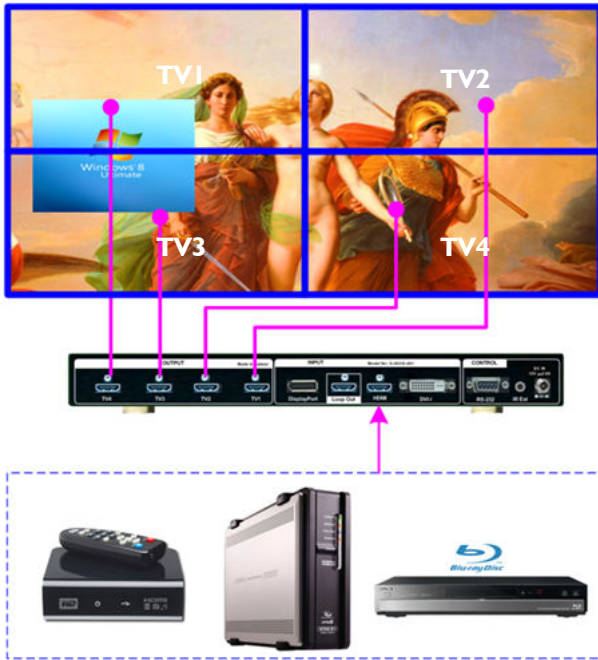

6.4 Preset mode: Mode 03

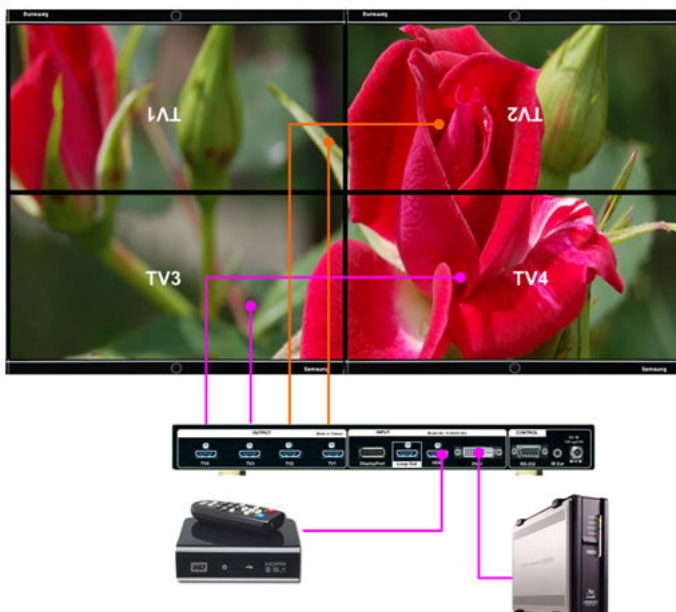

[Display Mode] DIP SW #1 is set at “ON” position. It will show 2x2 video wall. Connect MLT-PROWALL-4K outputs to related LCD

- a. TV1 to #1 LCD
- b. TV2 to #2 LCD
- c. TV3 to #3 LCD
- d. TV4 to #4 LCD

To check if Bezel compensation is required or not. If yes, please enable “Bezel” compensation DIP SW.

User can show dual contents in one 2x2 video wall.

To select PIP Input source and set [PIP Mode] at [POP Full] position, user will get full screen POP image.

User can select [POP Raw] to keep original aspect ratio in two contents.

Please see section 5.3 for more details.

Power OFF/ON the system again.

1. [Display Mode] DIP SW #3 is set at “ON” position.
2. Connect MLT-PROWALL-4K outputs to related LCD
 - a. TV1 to #1 LCD
 - b. TV2 to #2 LCD
 - c. TV3 to #3 LCD
 - d. TV4 to #4 LCD
3. To check if Bezel compensation is required or not. If yes, please enable “Bezel” compensation DIP SW.
4. **Top two TVs are installed at Down Flip position so that the adjacent edges of the TVs have the same bezel size. (please activate [Image Properties] - [Orientation] - select image direction)**



7 Multiple MLT-PROWALL-4K Cascade

7.1 Setup procedures

Multiple MLT-PROWALL-4K can be cascaded up to 15X15 MLT-PROWALL-4K. Below is the procedures for the setting:

- To connect signal to all MLT-PROWALL-4K. Maximum input resolution is 3840x2160 @30Hz.
- To connect IR receiver from each MLT-PROWALL-4K back panel.
- Use IR remote control to execute OSD command.
- To set Box ID # under [Options] [Settings] [Box ID] menu (1-9). It is for easy control for each MLT-PROWALL-4K.

Press “851” on remote controller, only the commands in #1 MLT-PROWALL-4K can be executed.

Press “852” on remote controller, only the commands in #2 MLT-PROWALL-4K can be executed.

Press “853” on remote controller, only the commands in #3 MLT-PROWALL-4K can be executed.

Press “850” on remote controller, the commands can be executed in all MLT-PROWALL-4K simultaneously.

7.2 Signal source resolution selection

Correct signal source resolution setting will optimize final video quality. Please try different resolution settings to get the best result. User can select below resolution settings:

Horizontal: 1920 or 3840 Vertical: 1080 or 2160

5.1 For single MLT-PROWALL-4K, to apply 1920x1080 @60Hz input resolution will get the best video quality.

5.2 For dual MLT-PROWALL-4K horizontal cascade, 3840x1080 @60Hz will get the best video quality.

5.3 For 2x2 four MLT-PROWALL-4K cascades, 3840x2160 @30Hz input resolution will get the best video quality. 5.4

For more complicated cascade, please follow the instruction in below section.

7.3 Case study A: 4k/2k 4x4 video wall

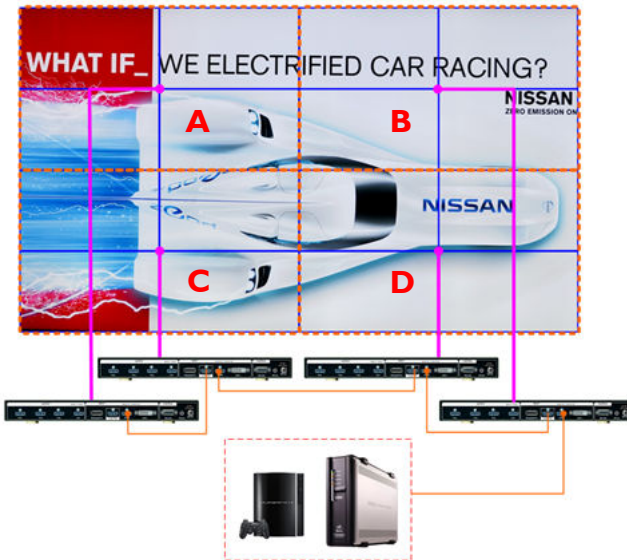

- Each MLT-PROWALL-4K will handle one display zone.
- Connect source signal to all MLT-PROWALL-4K via daisy chain.
- Set Display Mode 01 for all units of MLT-PROWALL-4K.
- Video wall setting in MLT-PROWALL-4K:

Items	Zone A	Zone B	Zone C	Zone D
Zoom	H=2, V=2	H=2, V=2	H=2, V=2	H=2, V=2
Pan	H=1, V=1	H=2, V=1	H=1, V=2	H=2, V=2
Overlap	RH/Btm	LH/Btm	RH/Top	LH/Top

- If only single signal source is available, please use HDMI loop out port for daisy chain connection.
- To fine-tune image position among display zone A/B/C/D by video wall [Overlap] setting.
- During [Overlap] adjustment, the image may have frame tear. It will disappear after power ON again.
- Save the final setting to OSD [Options] -[Settings] [Profile] - [Save] -[Index 1-5]. User can recall it at any time.



7.4 Case study B: 4k/2k 3x3 video wall

- Select preset display mode: Mode 35/36
- Connect the same signal to all MLT-PROWALL-4K.
- Video wall setting in MLT-PROWALL-4K

Items	Zone A	Zone B	Zone C
Zoom	H=1, V=3	H=1, V=3	H=1, V=3
Pan	H=1, V=1	H=1, V=2	H=1, V=3
Overlap	Bottom	Top/Btm	Top

- Video distributor is required to feed the same signal to all MLT-PROWALL-4K.
- To set overlap pixels to fine tune the image position among each MLT-PROWALL-4K if necessary.
- During [Overlap] adjustment, the image may have frame tear. It will disappear after power ON again.
- Save the setting to [Profile] under [Options] [Settings] menu.

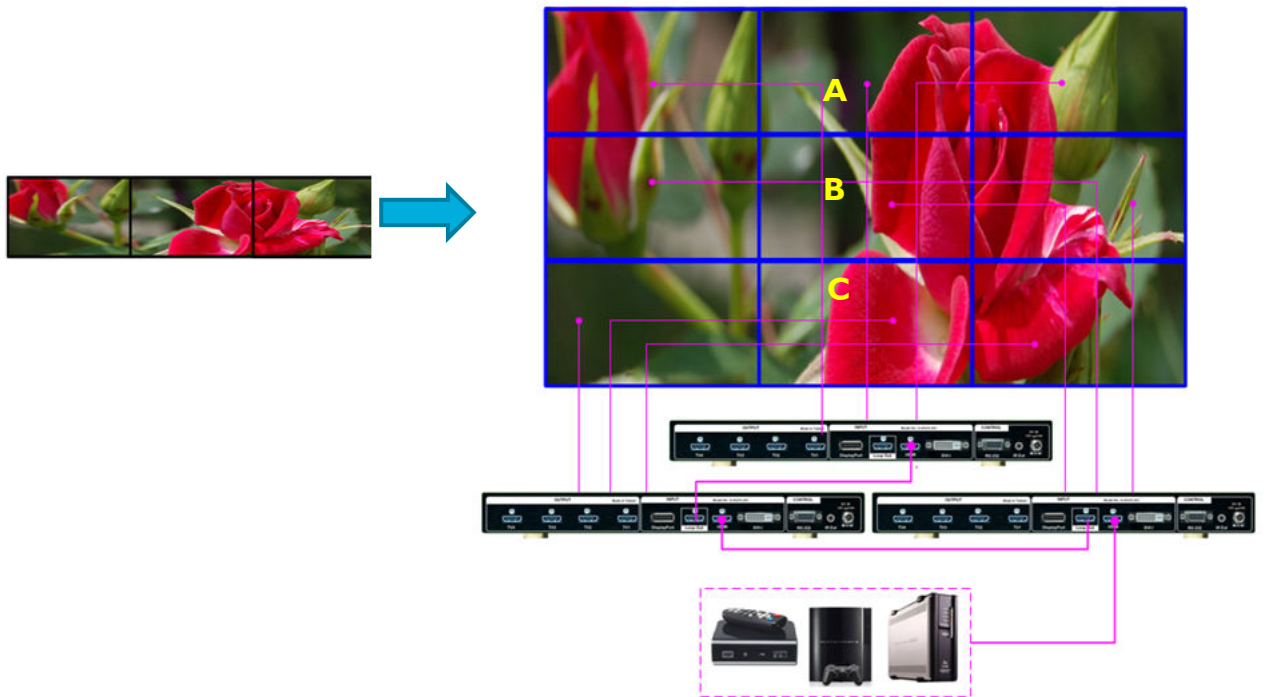

7.5 Case study C: 4k/2k 8x TV irregular video wall

- Select preset display mode: Mode 126/134
- Connect the same signal to all MLT-PROWALL-4K.
- Video wall setting in MLT-PROWALL-4K

Items	Zone A	Zone B
Zoom	H=2, V=1	H=2, V=1
Pan	H=1, V=1	H=2, V=1
Overlap	RH Edge	LH Edge

Overlap pixels for Zone A (Display Unit A) & B (Display Unit B) shall be the same. User can open [Overlap] menu and select [RH Edge] for A & [LH Edge] for B, then increase the [Overlap] value gradually in both [Display



Unit A] & [Display Unit B] and will see two images from both MLT-PROWALL-4K coming closer until the image edge match together.

- d. During [Overlap] adjustment, the image may have frame tear. It will disappear after power ON again
- e. Save the setting to [Options] [Settings] [Profile] [Save] [Index 1-5] menu.

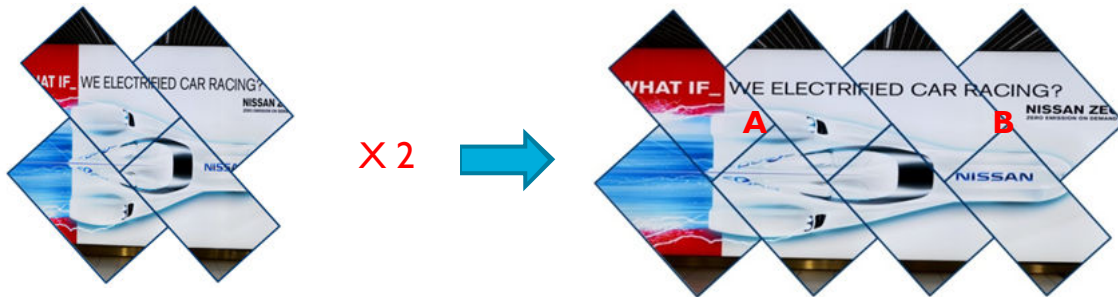

Note:

- 1. During [Overlap] adjustment, the image may have frame tear because the parameter is just temporary store in the system. Once the system has been powered OFF/ON again, the settings will be stored into the system and frame tear phenomenon will disappear permanently and will not happen again.
- 2. Please enable [Frame Lock] function under [Options] [Setting] menu to make sure all MLT-PROWALL-4K will synchronize with the input signal without frame tear or image lag. Default is [Enable].

8 Multiple contents in cascaded display

User can select different input source for Display Unit A & B and set video wall [Zoom] H=1, V=1 in both MLT-PROWALL-4K to display different contents in the video wall. It can be saved into another [Index]. User can switch between different Indexes to show different display styles—one content or dual contents in the video wall.

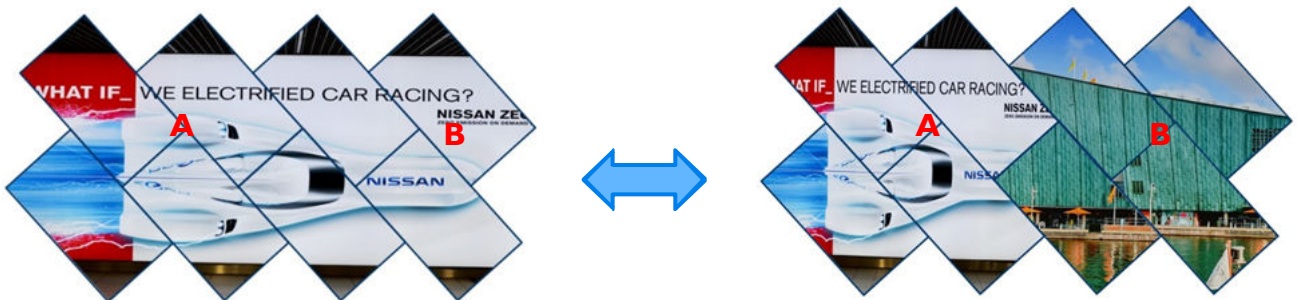

User can use PIP/POP function to add more display content in each display zone. In this case, the maximum display contents will be up to 4 in the above video wall.



9 Examples for cascaded display

* 2x Mode 35/36, recommended signal source resolution: 1920*2160

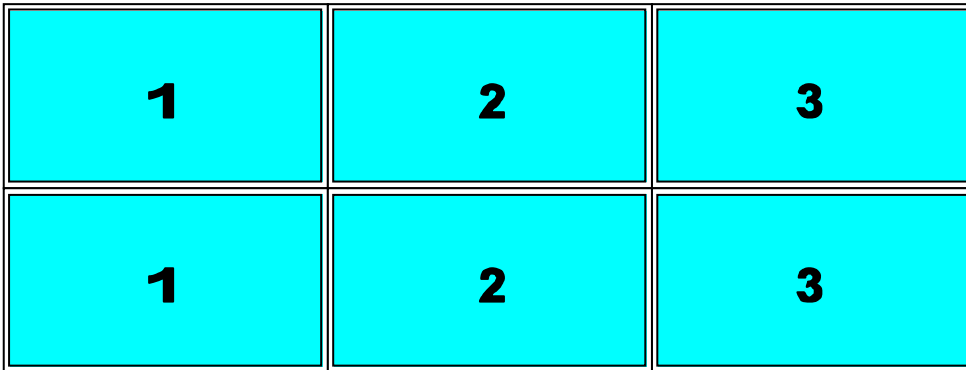

* 3x Mode 35/36, recommended signal source resolution: 1920*2160

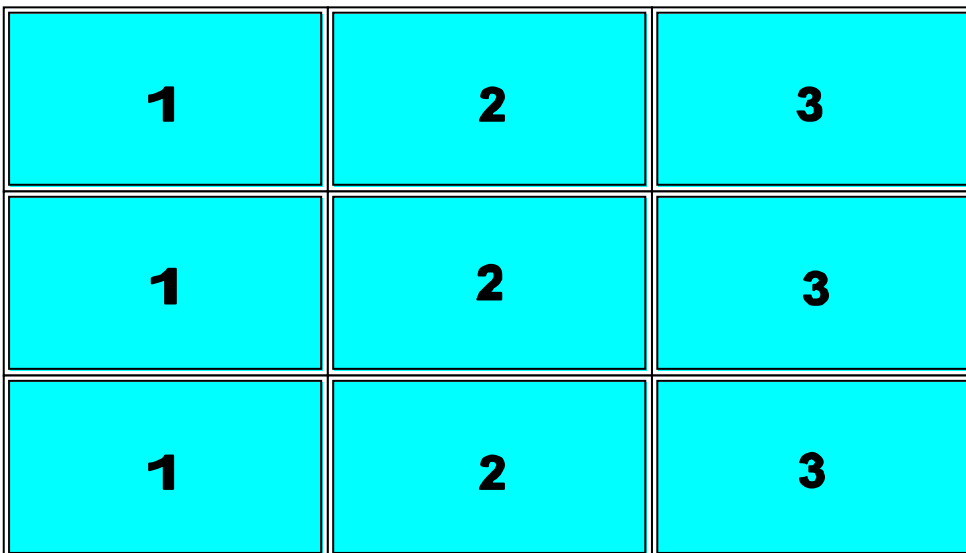

* 4x Mode 01/02, recommended signal source resolution: 3840*2160

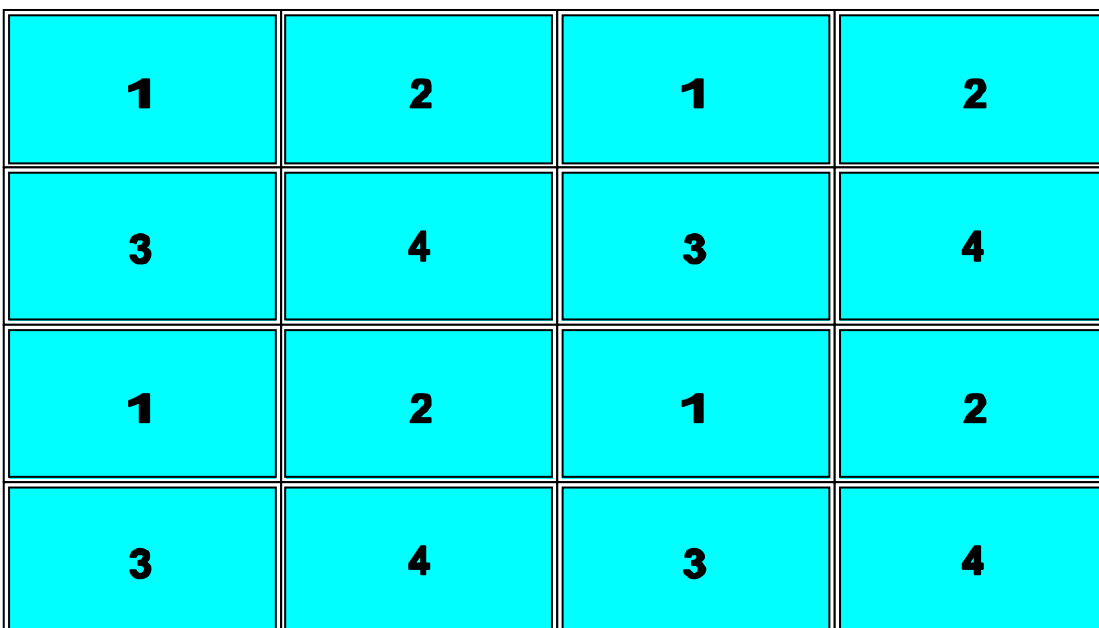

* 2x Mode 04/05, recommended signal source resolution: 1920*2160

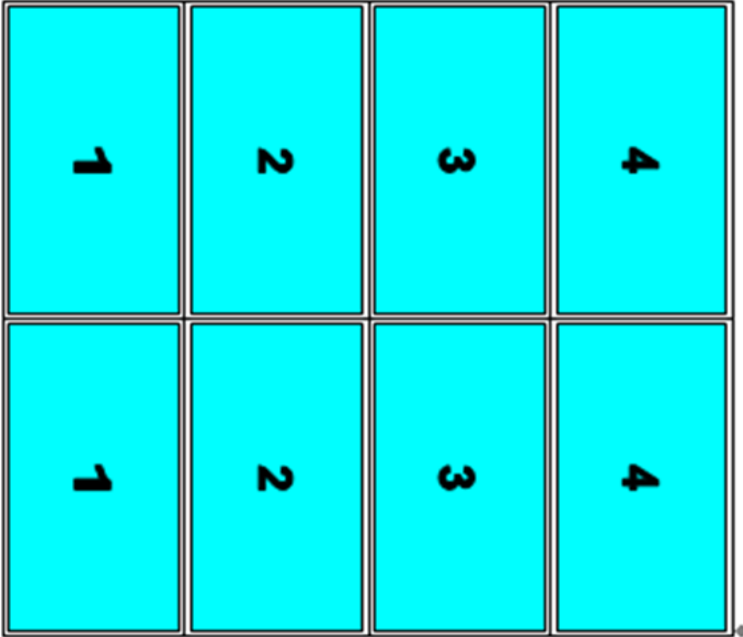

* 2x Mode 06/12, recommended signal source resolution: 1920*2160

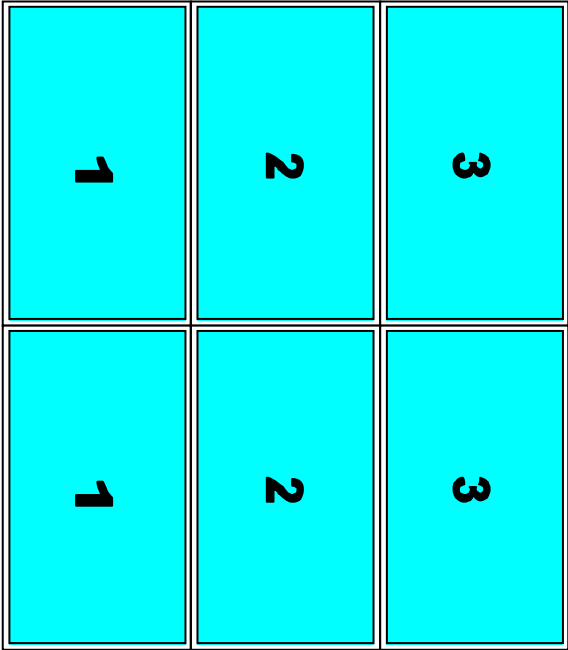

* 2x Mode 01/02 with 90rotation, recommended signal source resolution: 3840*1080

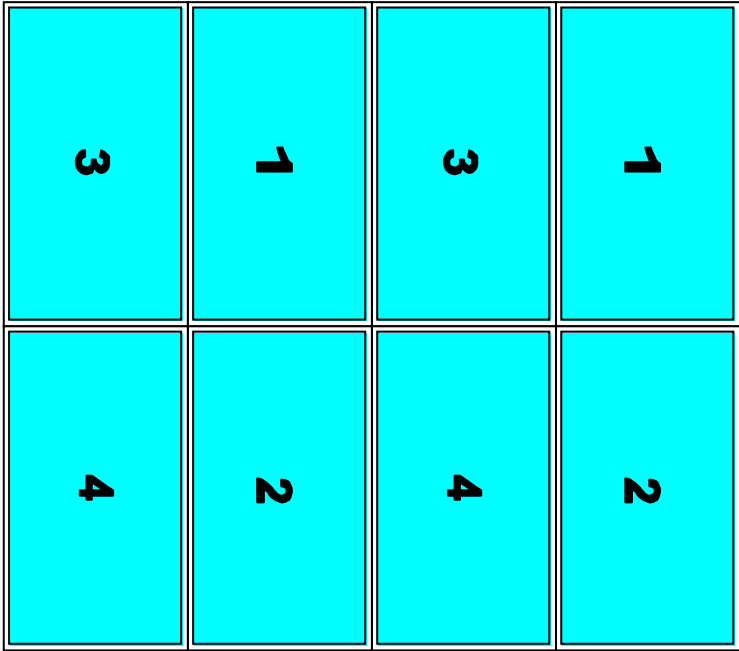

* 2x Mode 06/12 + 1x Mode 01/02 with 90rotation, recommended signal source

resolution: 3840*2160. Please see below [Video Wall] settings.

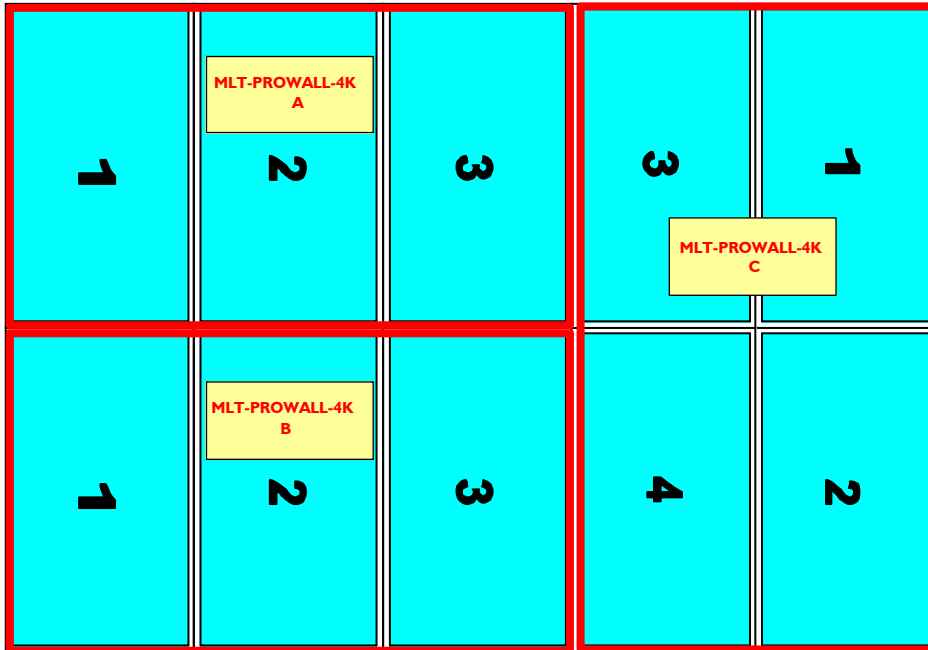

ZOOM:
 MLT-PROWALL-4K A&B:
 $H=2 \cdot V=2$ MLT-PROWALL-4K
 C: $H=2, V=1$ PAN:
 G-402A: $H=1 \cdot V=1$ MLT-
 PROWALL-4K B: $H=1 \cdot V=2$
 MLT-PROWALL-4K C:
 $H=2 \cdot V=1$ OVERLAP:
 MLT-PROWALL-4K A&B: RH
 "+" MLT-PROWALL-4K C:LH "-"

* 4x Mode 06/12, recommended signal source resolution: 3840*2160

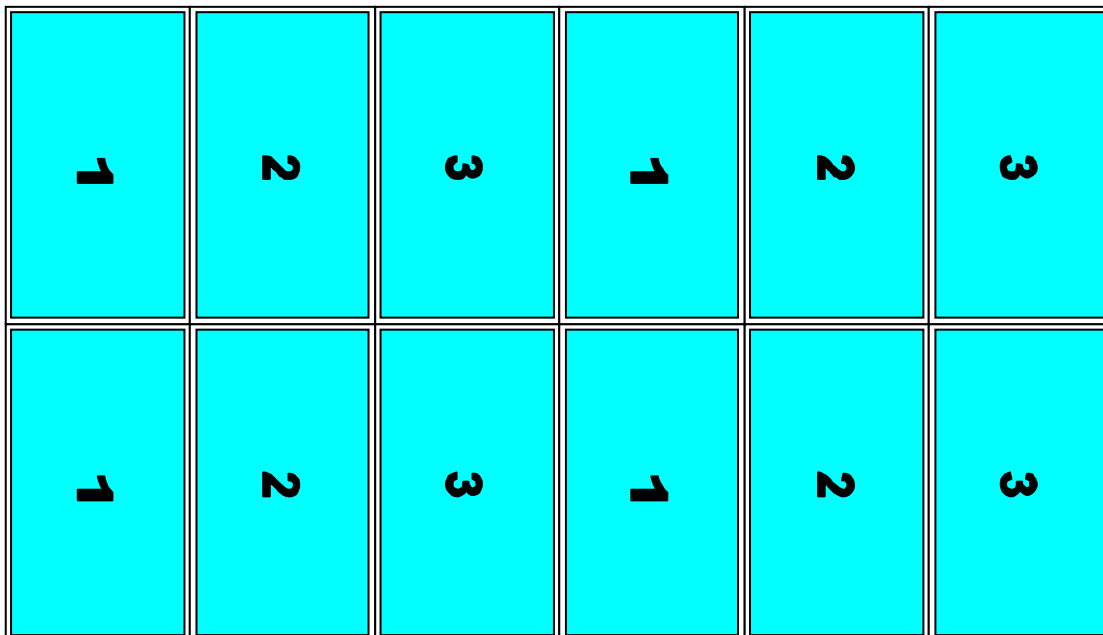

* 2x Mode 56/123, recommended signal source resolution: 1920*2160

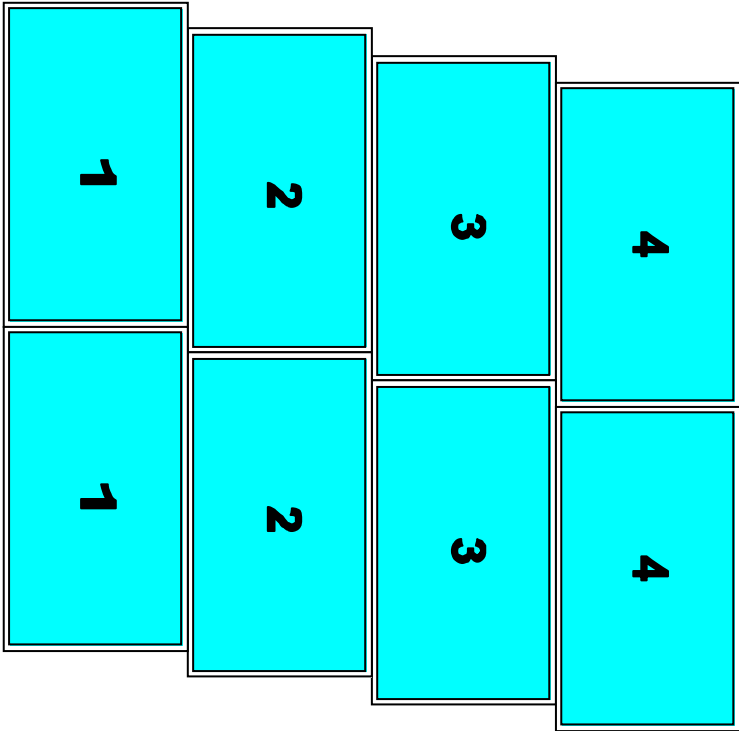

* 4x Mode 13/14, recommended signal source resolution: 3840*2160

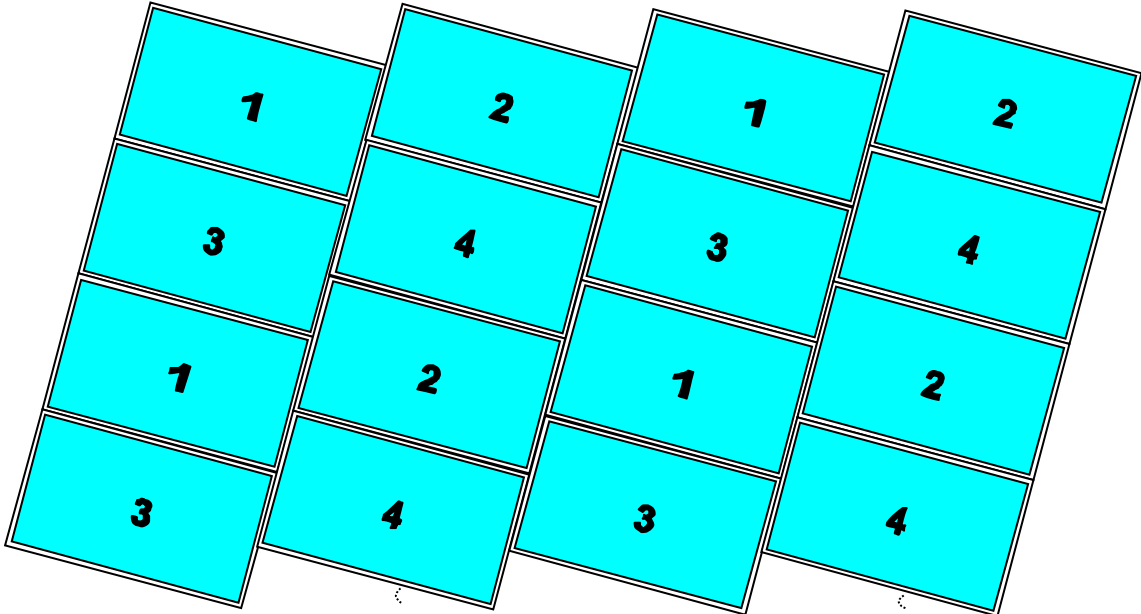

* 4x Mode 45/46, recommended signal source resolution: 3840*2160

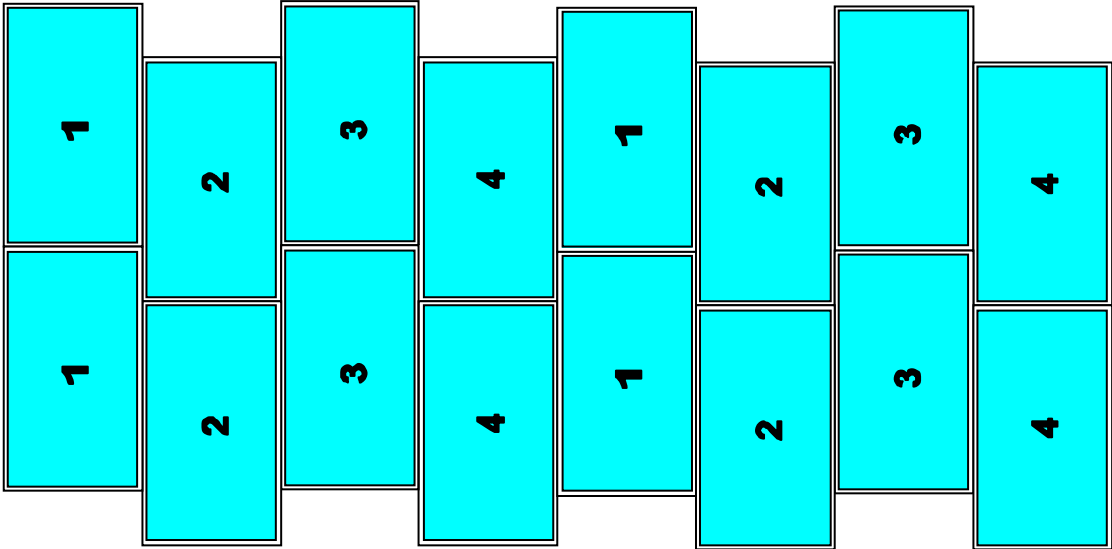

* 4x Mode 56/123, recommended signal source resolution: 3840*2160

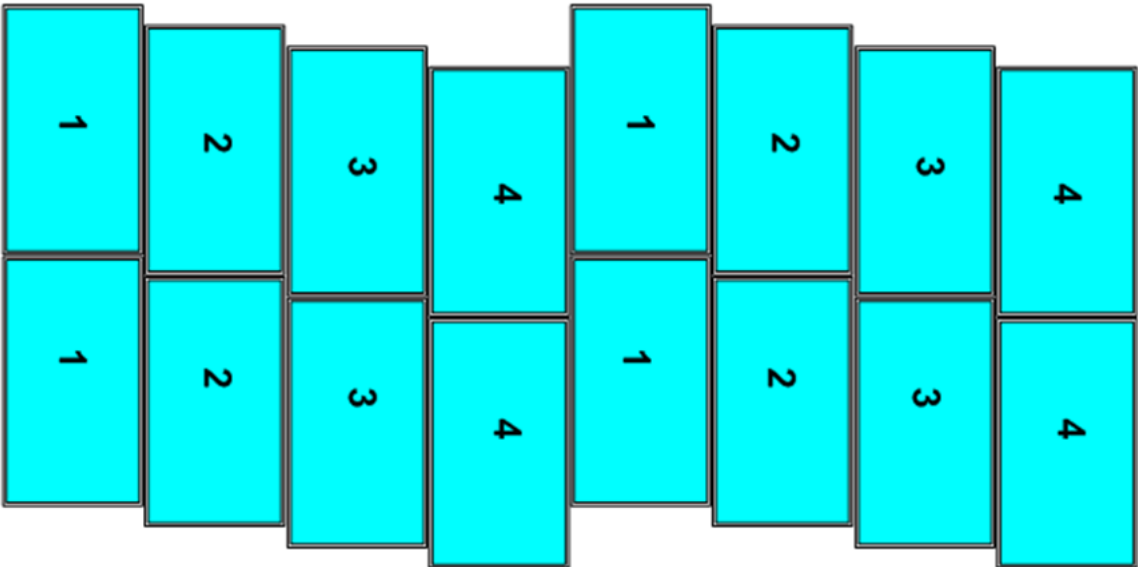

* 4x Mode 56/123, recommended signal source resolution: 3840*2160

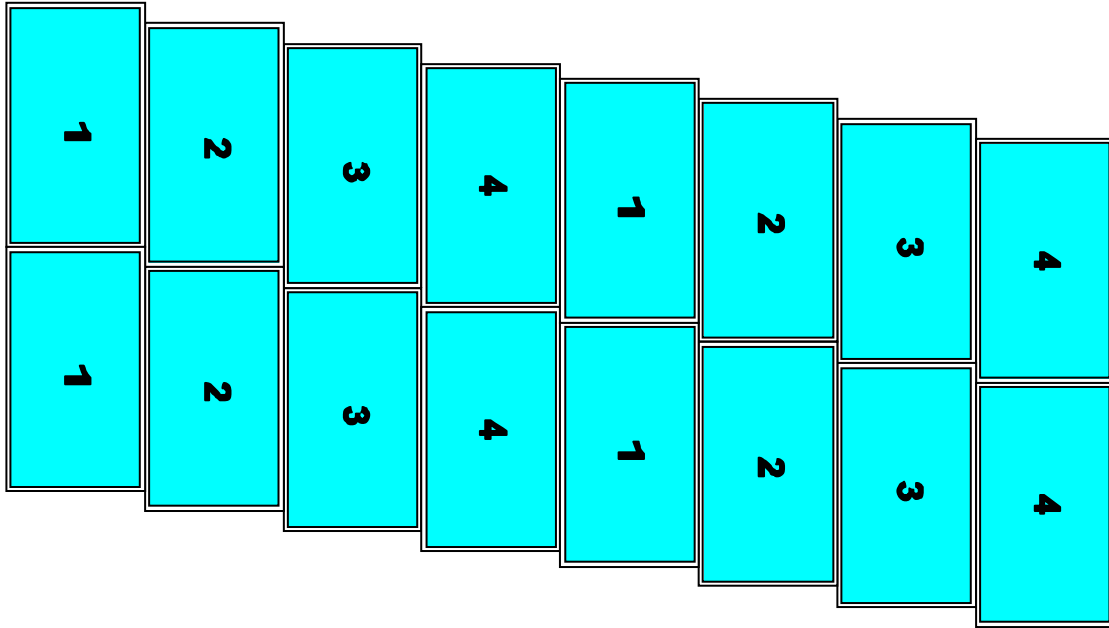

* 2x Mode 145/146, recommended signal source resolution: 3840*1080

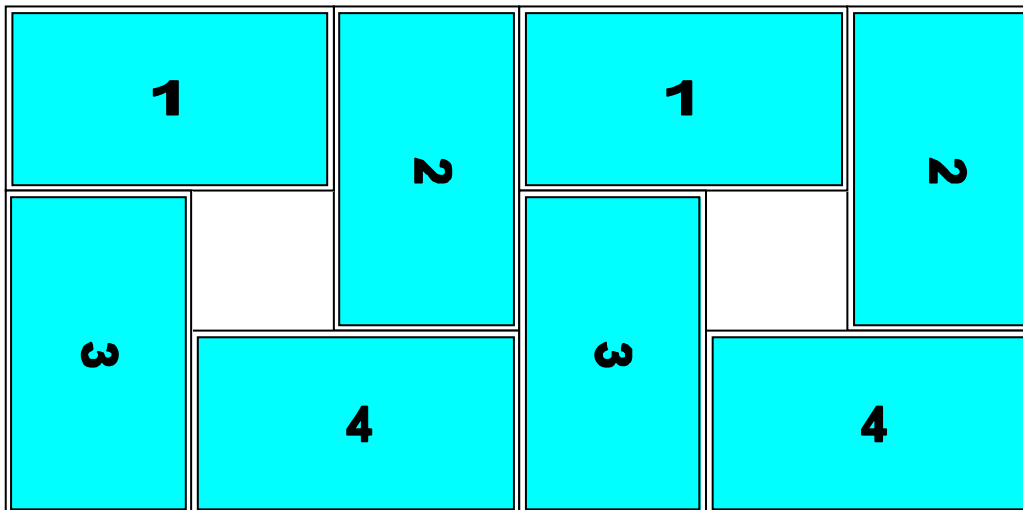

* 4x Mode 24/25, recommended signal source resolution: 3840*2160

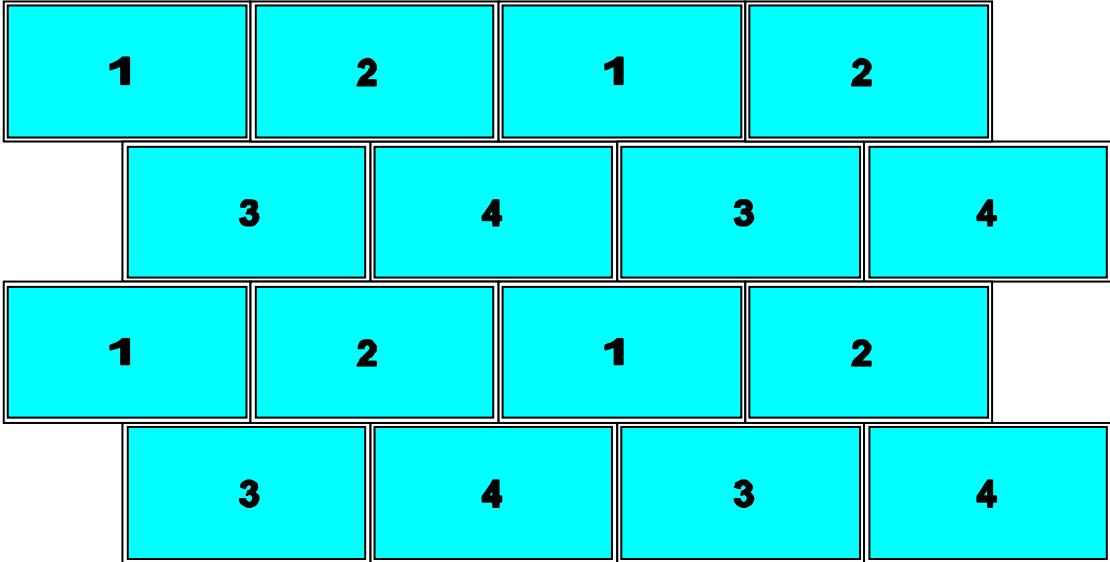

* 2x Mode 126/134, recommended signal source resolution: 3840*1080

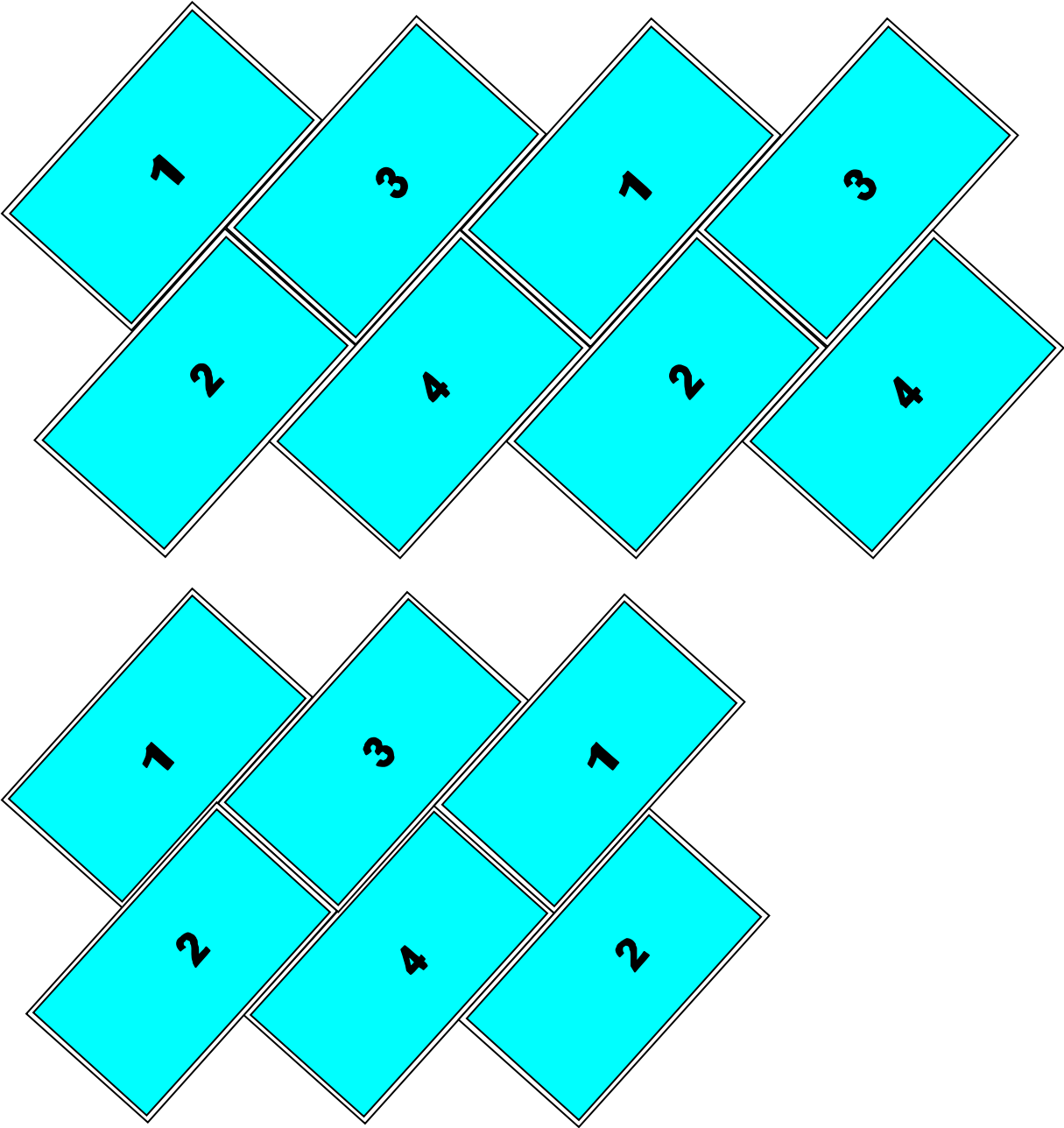

* 4x Mode 16/23, recommended signal source resolution: 3840*2160

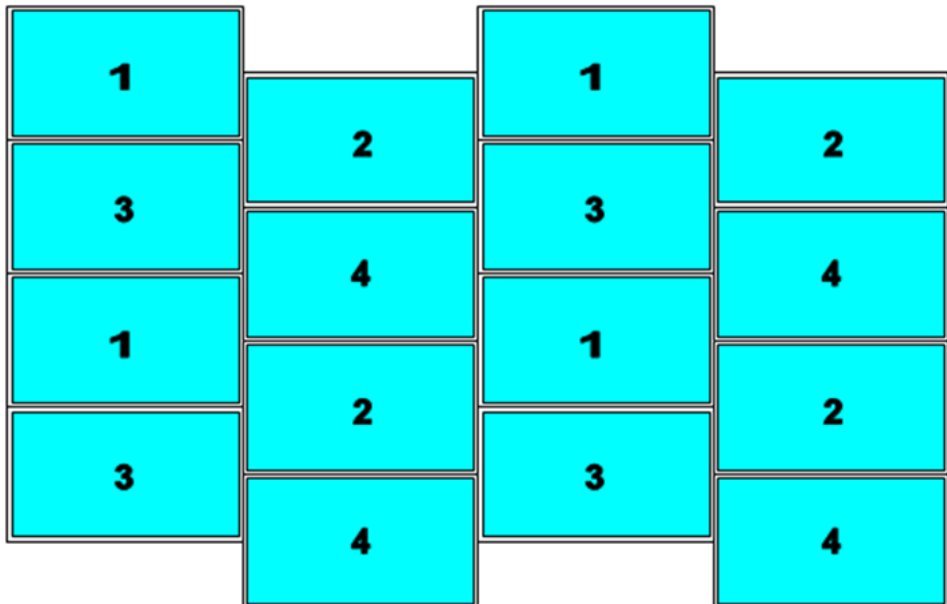

* 4x Mode 124/125, recommended signal source resolution: 3840*2160

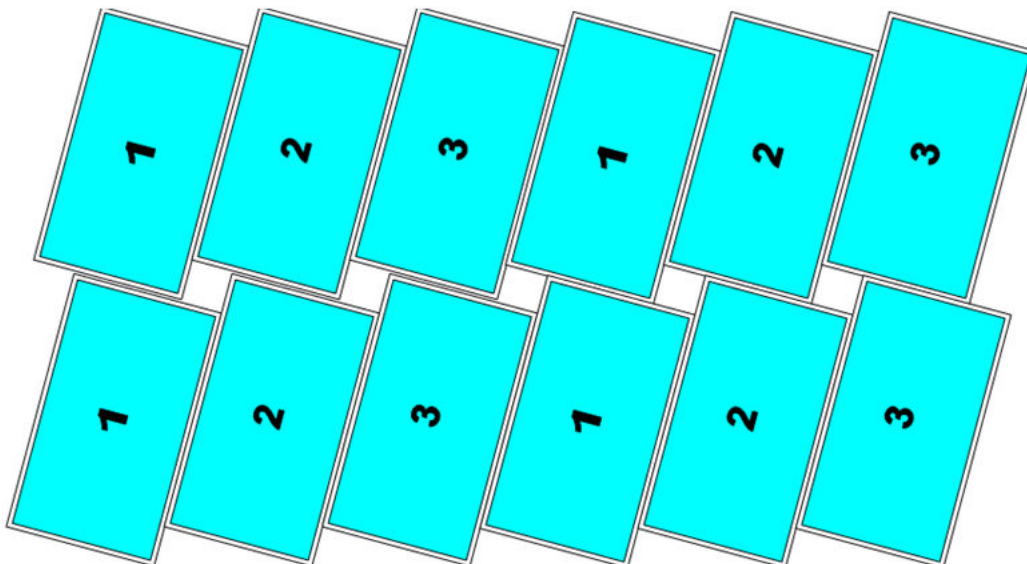

* 4x Mode 124/125, recommended signal source resolution: 3840*2160

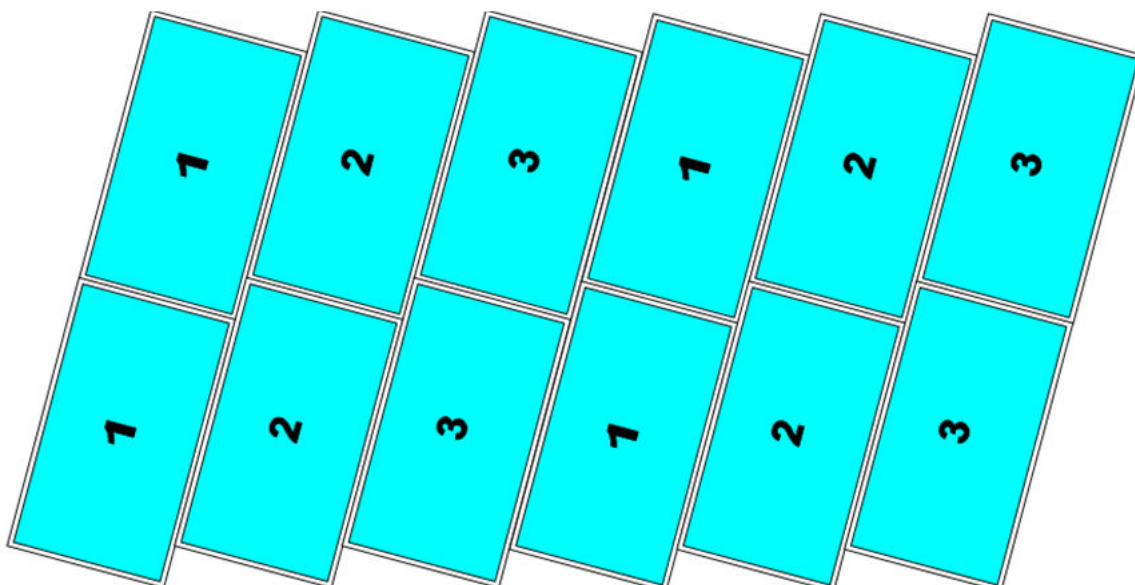

* 2x Mode 156/234, recommended signal source resolution: 3840*1080

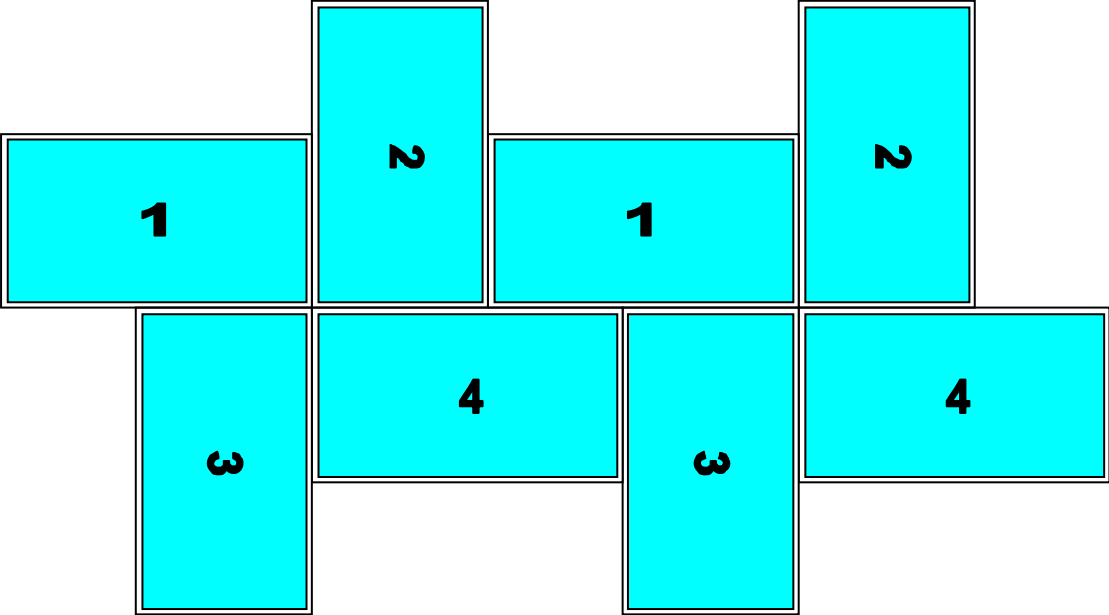

10 OSD menu and functions

Important notice:

1. Please set all Dip SW on [Main Input] at OFF position to assign system control authority to OSD menu so that OSD setting will be executed while the system is powered OFF & ON.
2. If any Dip SW in [Main Input] is not at OFF position, when the system is Power OFF and Power ON again, the system will check the Dip SW setting and execute the command in Dip SW setting. It will not implement the settings in OSD or settings stored in [Profile Index]. Under this condition, if user wants to implement previous setting, user needs to use remote controller to load the setting from [Profile] [Load] [Index 1-5] or use RS-232 command to load Profile [Index] settings.
3. After finished OSD operations, Please save OSD settings into Profile [Index] (see page 44) for long term reservation.
4. IR Remote Controller has Shortcut key for Profile [Index] loading function (see below picture).

OSD function is only available in MLT-PROWALL-4K model. User needs to connect IR extender module to the socket on the back panel and use IR remote controller to activate OSD menu and functions.

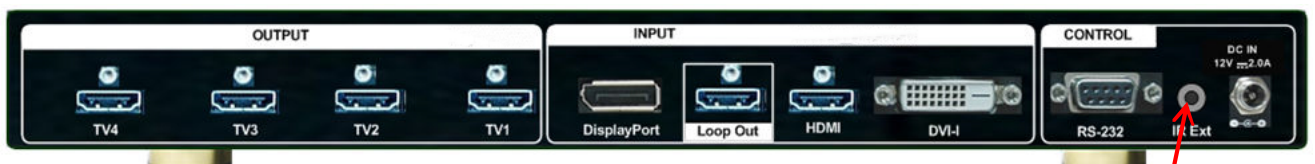

[OTH] Profile shortcut key to load Profile [Index]



IR remote controller

IR Receiver Extender

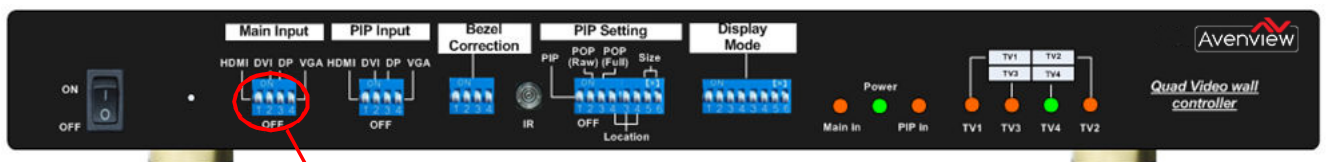

Please set all Dip SW on [Main Input] at OFF position to assign system control authority to OSD menu.

If user selects input port by Dip SW (at ON position), then when MLT-PROWALL-4K Ex is powered ON, the system will follow Dip SW setting to show the image. In this case, user will not see OSD setting result.



10.1 [Picture] Color Adjustment

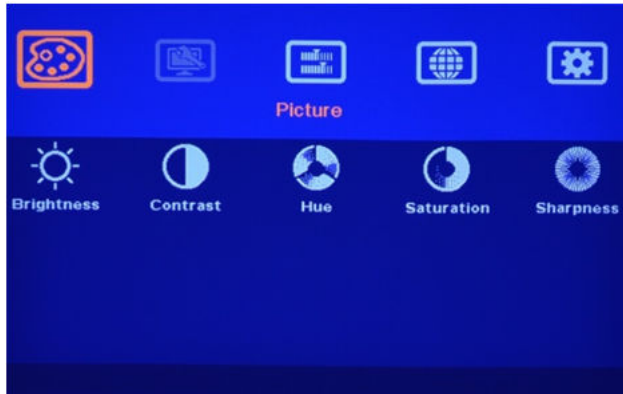

[Picture] menu is to adjust the color properties for the entire display unit (4x LCD). It can't do individual colour adjustment for each LCD. When the input signal is in YUV domain, all the items under menu are free to be accessed. If the input signal is in RGB domain, only [Brightness] and [Contrast] can be adjusted. User can do further separate RGB individual color adjustment under [Image Properties] menu.

10.2 [Image Setup] for PC graphics VGA input



[Image Setup] menu can only be activated when video input is from DVI-I input port with analog VGA input signal.

- a. Automatic: It will do automatic image alignment inside the system
- b. Manual: manual setting for signal Phase and Clock to eliminate image noise in analog input
- c. Horizontal Position: to adjust manually the image horizontal position.
- d. Vertical Position: to adjust manually the image vertical position.
- e. When the input is VGA signal, please connect signal to MLT-PROWALL-4K, then turn on MLT-PROWALL-4K for image position auto alignment. After this process, unless user applies other VGA input signal, MLT-PROWALL-4K will not do auto alignment again to avoid image shift.

10.3 [Image Properties]

[Image properties] is designed to select image colour temperature, adjust independent RGB colour, select input port, set display aspect ratio, set PIP setting and image flip/rotation. There are five sub-menus.

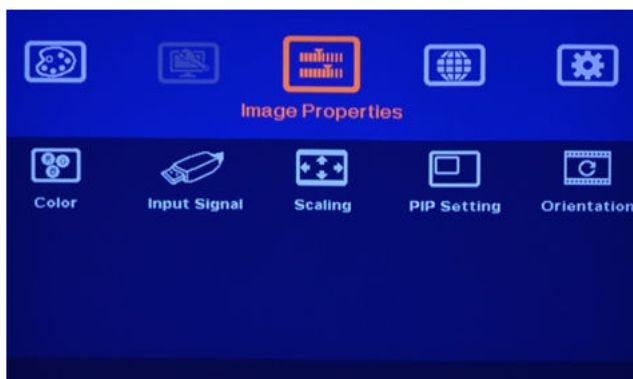

Five sub-menus:

[Color]: Colour temperature selection and RGB independent adjustment

[Input Signal]: to select input port

[Scaling]: to set display aspect ratio

[PIP setting]: to do PIP settings

[Orientation]: image flip and rotation setting



10.3.1 Color

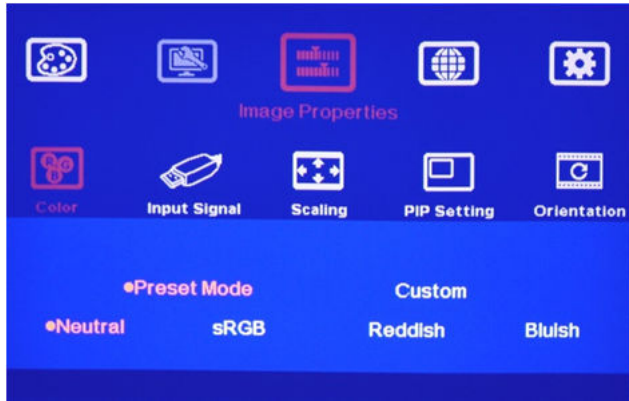

Under [Colour] menu:

- 4 Preset modes for colour temperature selection
- [Custom]: Independent RGB colour adjustment

10.3.2 Scaling

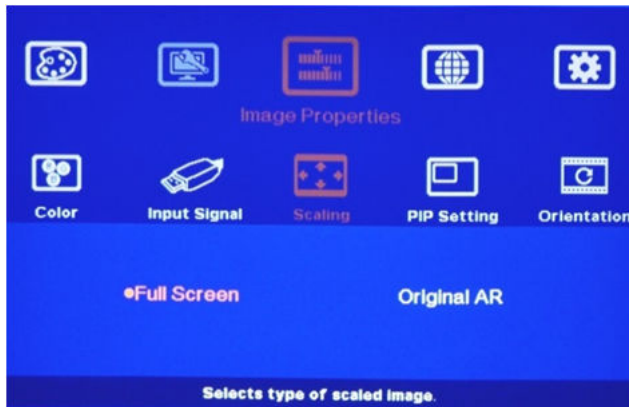

[Full Screen]:
To fit source image for full screen display

[Original AR]
To display source image with the same aspect ratio as source image

10.3.3 PIP/POP Setting (Picture in Picture & Picture outside Picture)

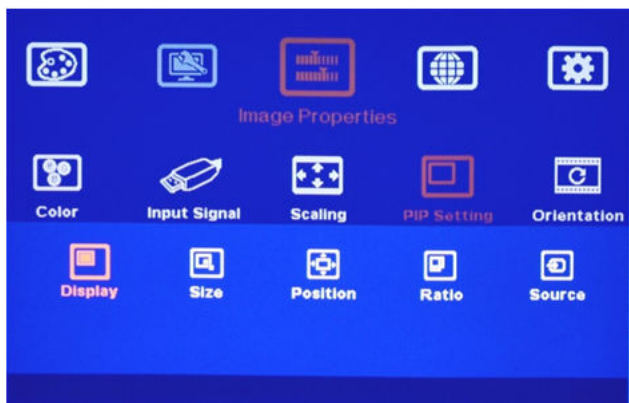

If user wants to keep PIP setting while system power on, user needs to set all [Main Input] Dip SW at OFF position and select input signal by OSD menu.

Dip SW PIP/POP setting has only preset image sizes and positions.

Picture in Picture (PIP) function is to display two images from one MLT-PROWALL-4K. The maximum size of the sub-image (PIP) is 1024x768 pixels. The input source for PIP is selectable and can be from any input port of MLT-PROWALL-4K. The input for main and PIP image can be the same or swapped. The location of the PIP image can be controlled by OSD menu at any location inside main image. The size of the PIP image is also flexible and can be controlled by OSD menu as well. Both main and PIP image will go through high end 3D motion de-interlacing. If a PIP/POP image is required to across multiple MLT-PROWALL-4K, then user can add one MLT-PROWALL-4K with PIP/POP function at the front end and connect the output to multiple MLT-PROWALL-4K



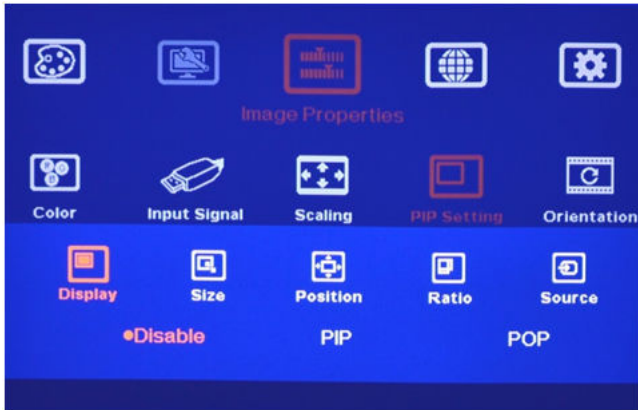

Five sub-menus under [PIP setting] menu, --
 Display: enable PIP or POP
 --Size: set PIP size
 --Position: set PIP size
 --Ratio: set PIP display aspect ratio
 --Source: select input source for PIP/POP

Display: Under Display menu, there are three choices.

Disable: to Disable PIP or POP function

PIP: to select PIP display function

PIP (Picture in Picture) mode



POP: to select POP (Picture outside Picture) display mode. User can select maintain original image aspect ratio or full screen mode through [Scaling] OSD menu under [Image properties]. If user set the system through Dip SW, user can select [POP Raw] and [POP Full] directly from front panel.

“POP” display mode with original aspect ratio

“POP” display mode with full screen mode



Size: (Only apply to PIP function)

The size of the PIP image can be adjusted through Size OSD menu pixel by pixel. The maximum size of PIP image is 1024x768 pixels.

Position: (only apply to PIP function)

The position of PIP image can be adjusted through Position OSD menu

The PIP image will be maintained inside main image and can't be outside the main image.

Pixel by Pixel PIP image position adjustment can be implemented by continuously Horizontal and Vertical position adjustments.

Ratio: Aspect Ratio of the display image. (Only apply to PIP function)



Full Screen: the same aspect ratio as main image or

Original AR: the same aspect ratio as PIP input source.

POP image aspect ratio can be adjusted through [Scaling] under [Image Properties] OSD menu. **Source:** can select the input source for PIP/POP image from all input ports. By selecting different input ports for Main & PIP/POP images, user can have different combination of the display. User can save different settings into [Profile] under [Option] menu and recall at any time.

10.3.4 Image Orientation (Flip):

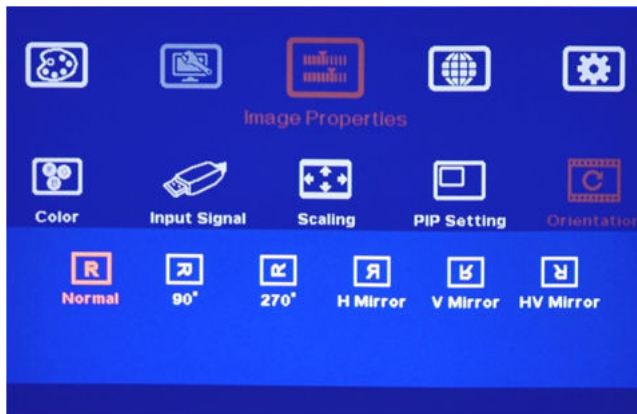

This image orientation function will be applied to entire display units (4x LCD).

Major purpose:

- To create more Display Modes based on Pre-defined Display Modes.
- To enhance and get more flexibility in multiple MLT-PROWALL-4K cascade applications.

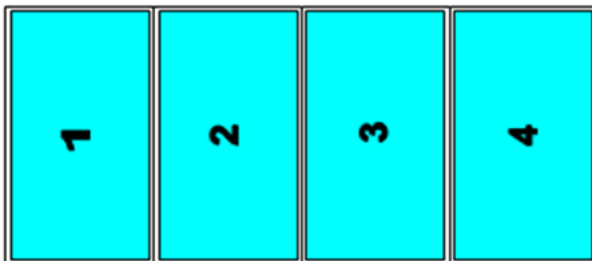

Original preset
Display Mode # 05

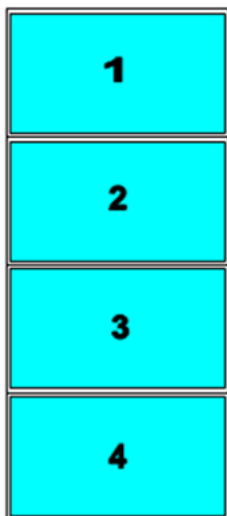

After 90 rotation
Display Mode # 05A

□ Display Mode #5 is preset in MLT-PROWALL-4K □
When user rotate image at 90, a new display mode #05A can be achieved in MLT-PROWALL-4K
□ 4x MLT-PROWALL-4K with Mode #5 with 90 rotation, user can get 4x4 video wall display.
□ User needs to provide 90rotated content to get normal display direction in this application case.
If user uses 4x MLT-PROWALL-4K with Mode #1, then it is not necessary to rotate the image and can get the same 4x4 video wall.



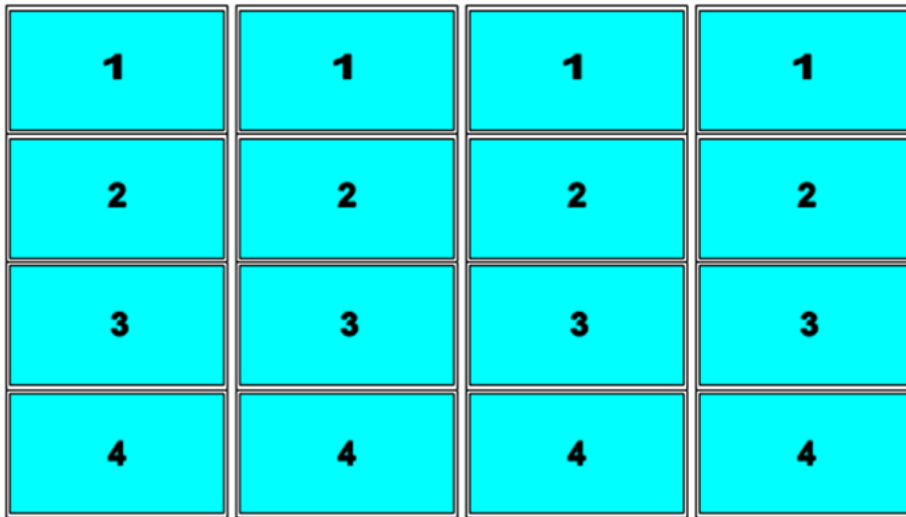

Cascade with 4x
MLT-PROWALL-4K
to get 4x4 4k/2k
video wall

10.4 Video Wall Setting

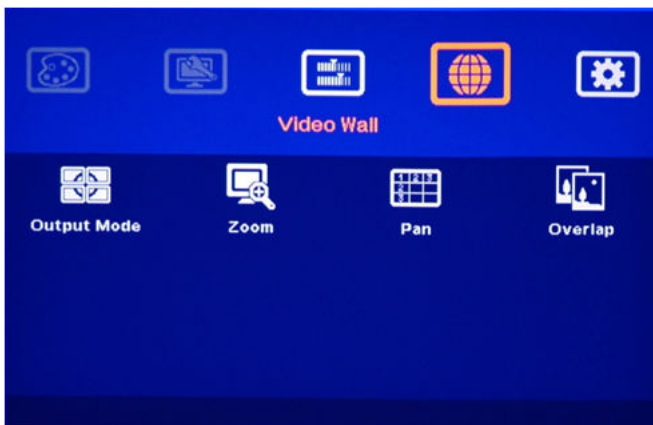

The purpose for Video Wall Setting is for cascade multiple MLT-PROWALL-4K to become one video wall display.

It consists below functions:

[Output Mode]: To show display modes on OSD for easy display mode selection

[Zoom]: To split source image into different section for each MLT-PROWALL-4K.

[Pan]: to assign each image section to each MLT-PROWALL-4K at the right location.

[Overlap]: to re-allocate each image section at the right location for the cascade to become a complete big video wall display.

The maximum video wall can be up to $15 \times 15 = 225$ MLT-PROWALL-4K. If each MLT-PROWALL-4K is connected with 4x LCDs, then theoretically the total number of the LCD display can be up to $30 \times 30 = 900$ LCDs from single signal source.

10.4.1 Output mode

[Output mode] shows pre-defined modes in MLT-PROWALL-4K. When user selects desired display mode, the mode # will be showed at the bottom.



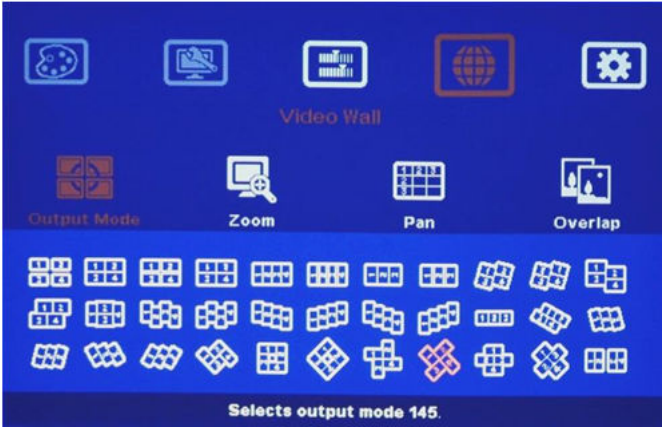

When user selects desired display mode, the mode # will be showed at the bottom.
 Mode # 145 is showed in left figure.
 User can set [Display Mode] Dip SW to get this display mode. If user doesn't set this mode in Dip SW, after turn off/on MLT-PROWALL-4K again, the display mode will be switched back to Dip SW setting mode.

10.4.2 Zoom

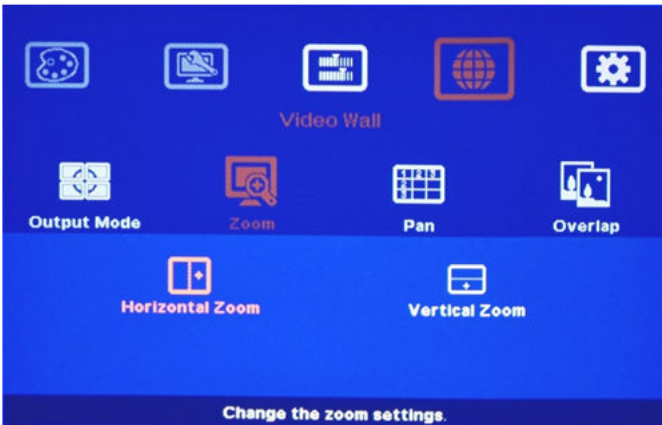

MLT-PROWALL-4K is designed with 3-4 LCDs as one Display Unit and the display modes are preset inside the system. User can't change display style inside each Display Unit.
 Zoom function is to split the source image content for different Display Units in multiple MLT-PROWALL-4K cascade applications.

User can set both Horizontal and Vertical Zoom value based on the array of the Display Units. In below example, each number means one Display Units (3-4 LCDs) and also means one MLT-PROWALL-4K.

Example A:



3x1 MLT-PROWALL-4K

horizontal cascade: --Horizontal

Zoom=3

--Vertical zoom=1

Example B:



In 3x3 MLT-

PROWALL-4KEx

cascade: --Horizontal

Zoom=3

--Vertical Zoom=3



10.4.3 Pan

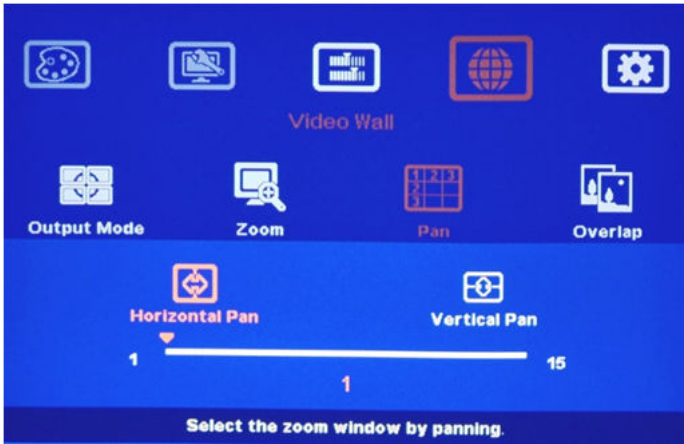

[Pan] is to assign the split image location for each Display Unit.
 Horizontal value is calculated from LH to RH direction and Vertical value is calculated from top to bottom.
 User needs to set H & V [Pan] value to assign the location for each MLT-PROWALL-4K to capture necessary section of the image to build a big video wall display.

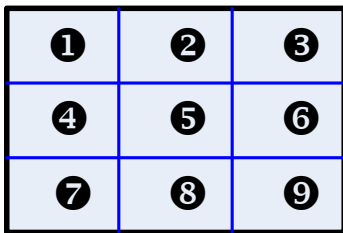

In 3x3 MLT-PROWALL-4K cascade application:
For No. MLT-PROWALL-4K: For No. MLT-PROWALL-4K:
Horizontal Pan = 3 Horizontal Pan = 3
Vertical Pan = 1 Vertical Pan = 2

10.4.4 Overlap

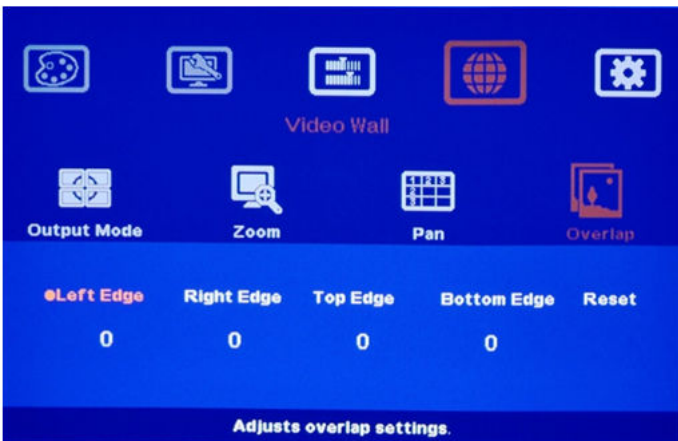

[Overlap] is to align the location of each Display Unit (MLT-PROWALL-4K) □
 User can adjust the image location in H&V position up to +_900 pixels.
 Through [Overlap] adjustment, user can align each Display Unit into the right position in the video wall to become a video wall display cascaded with multiple units of MLT-PROWALL-4K.

The [Overlap] value will change the image capture area and change image scaling factor. In multiple MLT-PROWALL-4K cascade application, the [Overlap] value adjustment in each MLT-PROWALL-4K should be the same so that the image will be the same size. User can use [Overlap] adjustment to change aspect ratio in video wall image.

10.4.5 Example for two MLT-PROWALL-4K cascade

(Please see more details in section 7)

Overlap pixels for Zone A (Display Unit A) & B (Display Unit B) shall be the same. User can open [Overlap] menu and select [RH Edge] for A & [LH Edge] for B, then increase the [Overlap] value gradually in both [Display Unit A] & [Display Unit B] and will see two images from both MLT-PROWALL-4K coming closer until the image edge match together.



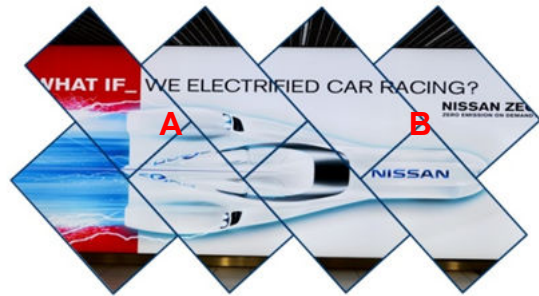

10.5 [Options]: OSD Miscellaneous Functions

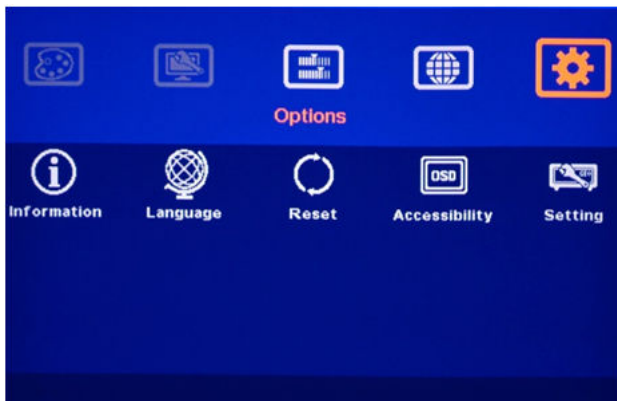

6 sub-menu under [Options]: -

- [Information]
- [Language]
- [Reset]
- [Accessibility]
- [Setting]

10.5.1 [Information]: System Information

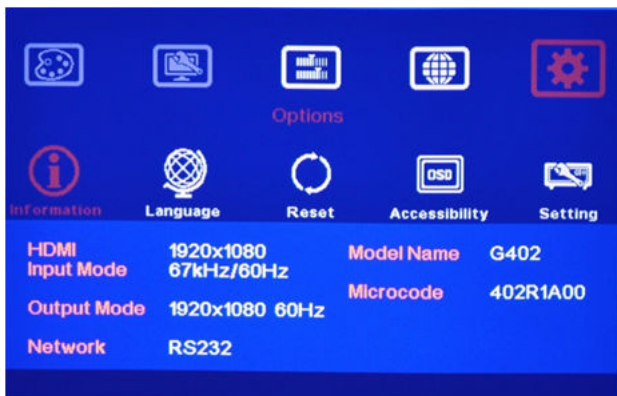

[Information] menu shows the following information in MLT-PROWALL-4K, such as Input mode, output mode, Network status, Model name and Firmware version.

10.5.2 [Language]: OSD Language

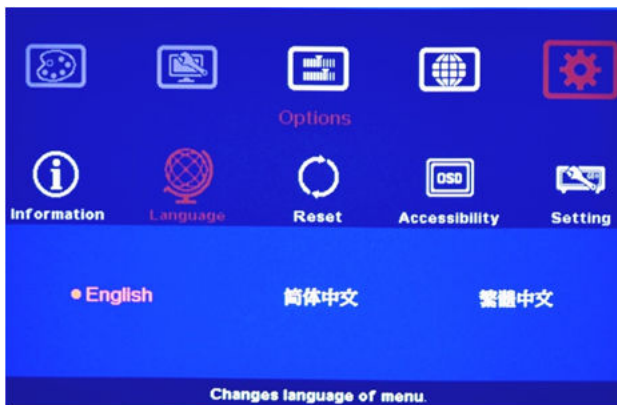

Three OSD menu languages can be selected:

English, Simplified Chinese and Traditional Chinese



10.5.3 [Reset]

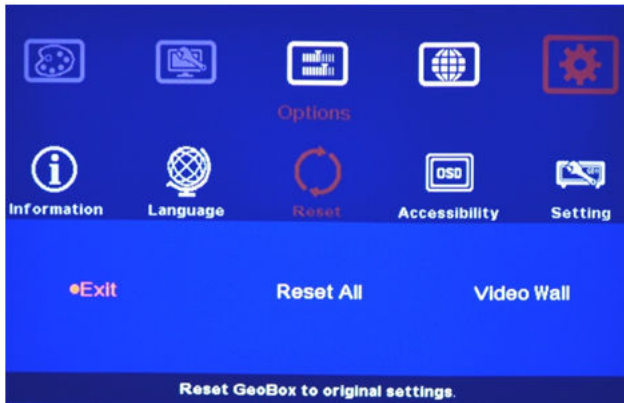

Two types of Reset can be done: Reset All & reset Video Wall.

[Reset All] will reset all user settings but the settings stored in [Profile] will be kept without change.

Reset [Video Wall] will reset the settings in Video Wall function to factory default.

10.5.4 [Accessibility]

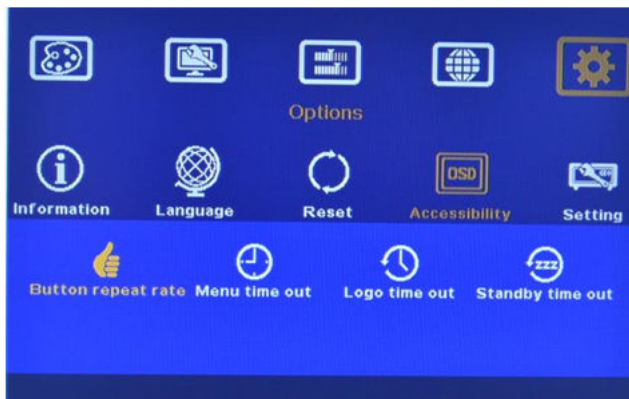

Four sub-menu under [Accessibility]:

OSD [Button Repeat Rate]

OSD [Menu Time out]

Splash screen [Logo Time Out]

No signal input [Standby time out]

10.5.4.1 [Button Repeat Rate]

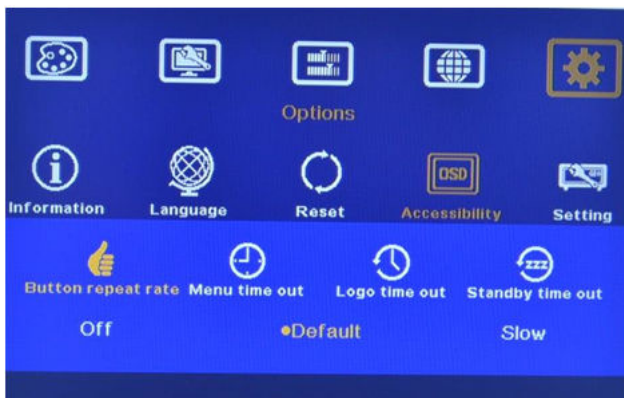

OSD [Button Repeat Rate]:

It controls OSD button response speed while user presses OSD button continuously.

10.5.4.2 [Menu Time Out]

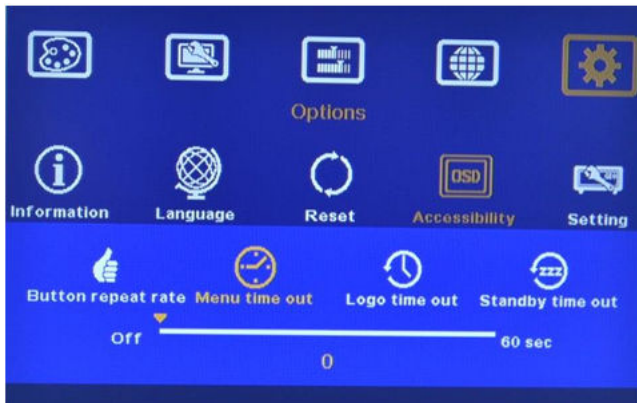

OSD [Menu Time Out]

OSD menu will disappear from the screen based on time setting.

The default time is 30 seconds.

[OSD Time Out] shortcut key is available on IR remote controller

When [Off] is selected, the OSD menu will remain in the screen until user activates other OSD



function or input/output mode change.

10.5.4.3 [Logo Time Out]

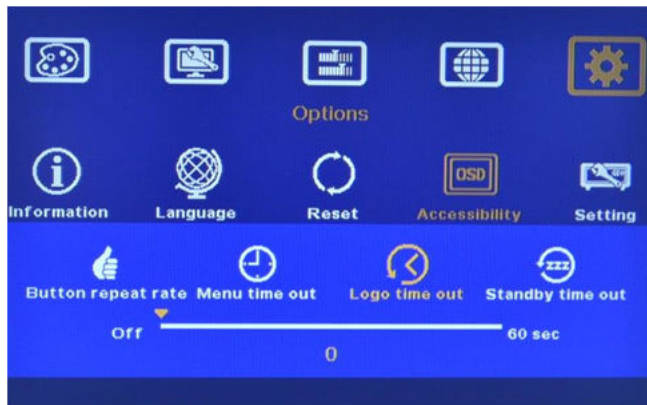

To set the time to show Splash screen.
If zero is selected, then the splash screen will not be showed during system booting up period.

10.5.4.4 [Standby Time Out]



The default setting for [Standby Time Out] is 60 seconds. MLT-PROWALL-4K will automatically cut off output signal if no input signal is detected after 60 seconds. The time can be set by user. If the time is set to "0", then MLT-PROWALL-4K will not turn off the output signal even no input signal is detected.

10.5.5 [Setting]

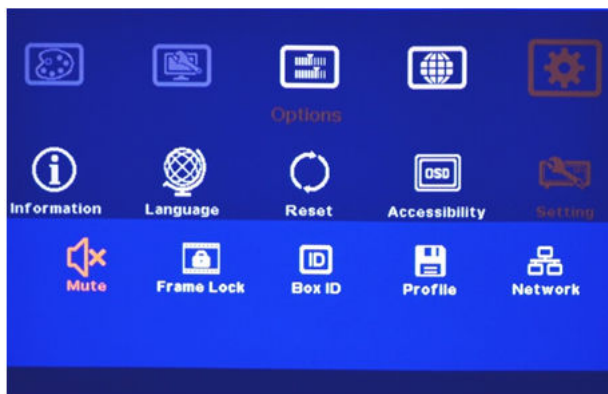

Five sub-menu under [Settings] menu:
[Mute] Audio mute or enable
[Frame Lock]: system synchronization
[Box ID]: Set control ID
[Profile]: Save profile settings
[Network]: set RS232 and network control

10.5.5.1 Audio [Mute]

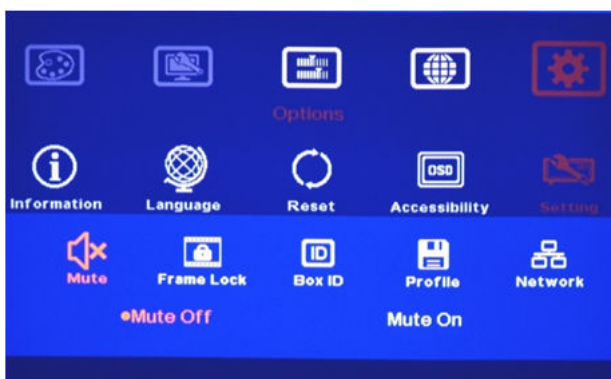

Audio Mute:
[Mute Off] will enable audio output.
[Mute On] will disable audio output.
[Mute] hot key in remote controller is available



10.5.5.2 Frame Lock and Free Run Mode

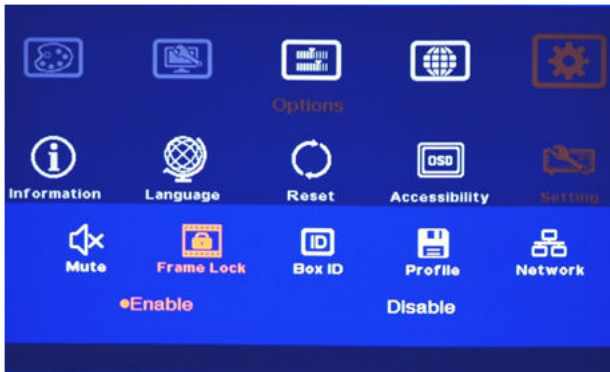

[Frame Lock] will ensure the input and output frame rate synchronize together. This is mainly for multiple MLT-PROWALL-4K applications. If [Flame Lock] is disabled, the system will be in [Free Run] mode and keeps continuous output timing. This will provide quicker input source or input timing change under below conditions:

- a. Input signal shall have the same refresh rate (i.e. 60Hz)
- b. No HDCP compliant signal.

It is possible to see frame tear artifact if [Frame lock] is turned off while in multiple unit application.

10.5.5.3 [Box ID]

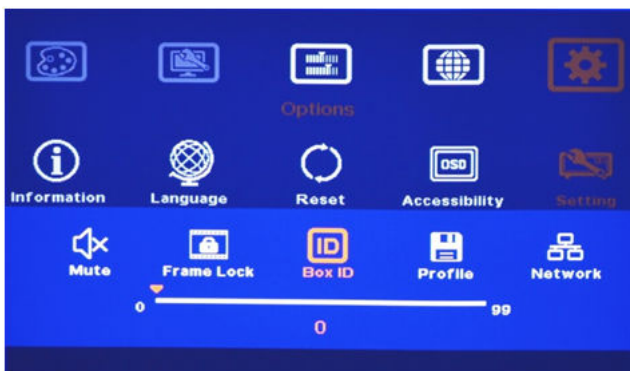

[Box ID] is identification # in each MLT-PROWALL-4K for individual RS232 or IR remote control.

MLT-PROWALL-4K ID No is from 1-99
After set Box ID, user can control MLT-PROWALL-4K individually via IR Remote controller, RS232 & Ethernet
IR control ID # is from 0-9 only.

10.5.5.4 [Profile] Setting

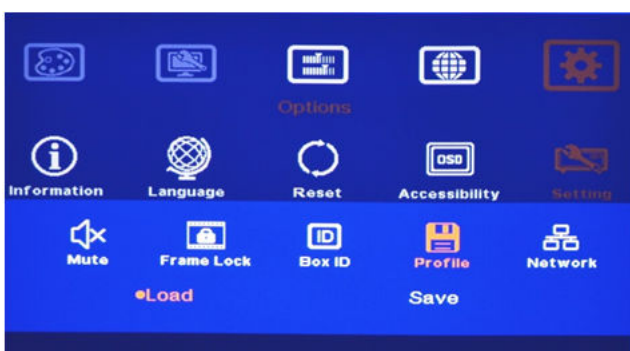

[Profile] is to save and load MLT-PROWALL-4K settings.

All settings from OSD menu need to be saved in [Profile] and recall it when the system is powered ON. Otherwise, user will only see the settings by Dip SW. Dip SW settings hold the 1st priority.

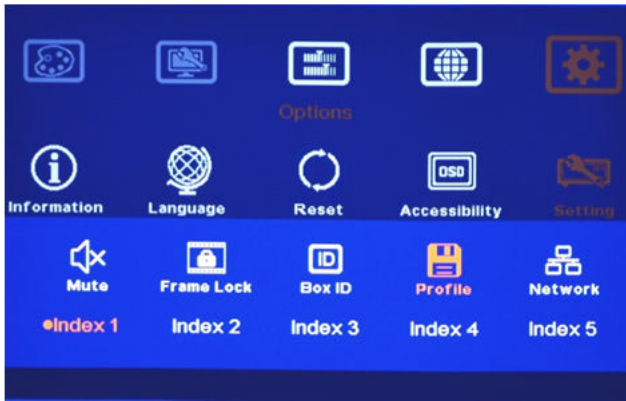

Five indexes can be chosen to save MLT-PROWALL-4K settings and can be recalled by IR remote controller or RS232 via [Load] menu under [Profile]

Application example: when cascade with two MLT-PROWALL-4K, user can set three display styles:

1. To show cascade image with single content across whole video wall.
2. To show two side by side contents across whole video wall.
3. To show one PIP content in cascaded image.
4. To show two PIP contents in cascaded image.

User can save these different display styles in MLT-PROWALL-4K and recall them by RS232 or remote controller.

Please note:

When execute system reset, Profile settings will remain the same without change.

If the settings in Dip SW on the front panel are different from the settings in [Profile], Dip SW setting will have the 1st priority. For example, if your Dip SW selects Display mode # 02 and you select mode #05 via OSD. Once you power OFF/ON the system again, it will show mode #02 but not mode #05. The same issue will happen in PIP/POP settings, if you select a position and size of PIP image by OSD menu, once you power OFF/ON the system, it will follow the setting in Dip SW but not OSD. You need to load the profile to get new OSD settings.

10.5.5.5 [Network]

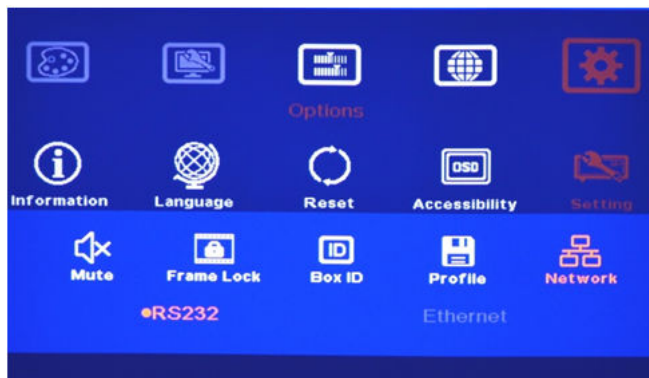

Only RS232 under this Menu.
User can use external UART to Ethernet converter to control MLT-PROWALL-4K through Ethernet control system.
User can use simple button type RS232 controller to switch among different Profile settings.



10.5.5.5.1 RS232 setting:

- a. Serial port setup



- b. Terminal setup

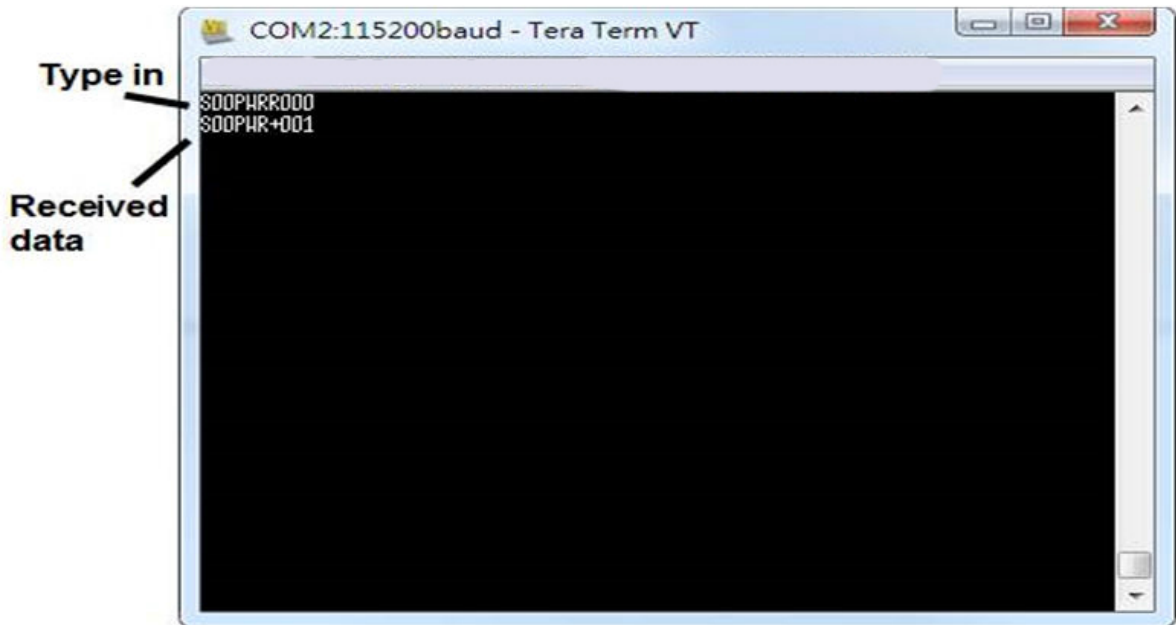

10.5.5.2 Example of low cost RS232 controller

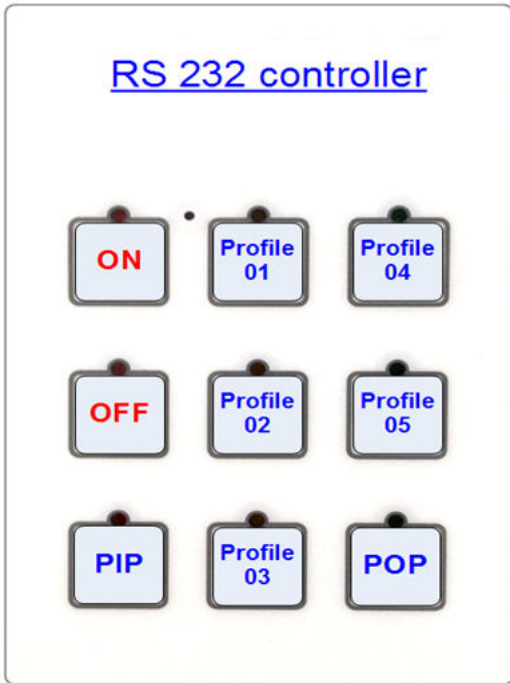

User can save up to 5 settings into [Profile].

User can connect this RS232 controller with each MLT-PROWALL-4K through RS232 cable in parallel. □

Click Profile button in RS232 controller to power on/off the system or select display Profile.

If separate RS232 control is required, user needs to set different [Box ID] for each MLT-PROWALL-4K and put ID # into RS232 command.

10.5.5.6 [EDID] setting

Selective EDID setting is added into MLT-PROWALL-4K. The purpose are as follows:

- c. MLT-PROWALL-4K can support big range of input signal timing—from SVGA up to 4k/2k. In order to get the best video performance, user needs to select different input signal resolution.
- d. Different PC display cards have different setting and behavior. Many users may not be able to do the right settings
- e. High end media player or server can support big range of outputs—from 720p to 4k/2k. If no EDID selection function, only one default EDID can be selected by media player. The system may not show the best video wall output quality.
- f. Different display modes may show different final image aspect ratio. User can utilize different EDID setting to change input signal timing and get different output image aspect ratio.

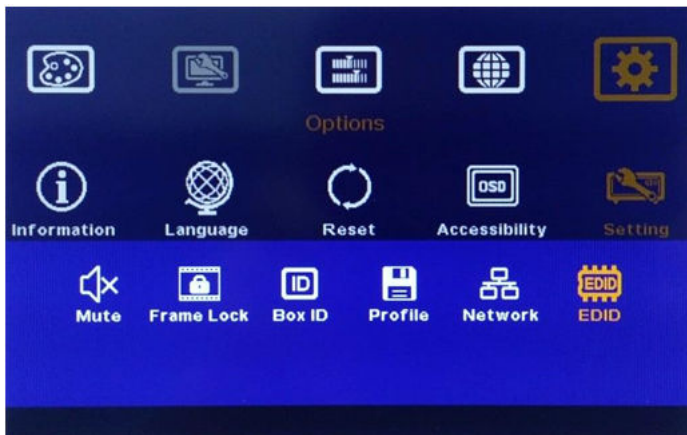

Activate EDID setting menu:
 [Options] □ [Setting] □ [EDID]

Use IR remote controller to select desired EDID.

After select EDID, the PC or medial will automatically change the output timing setting.

Press [INFO] key to check if the input and output timing are set correctly.





In very rare cases, some PC may not detect the right EDID from MLT-PROWALL-4K and show different result. If it happens, please open resolution setting window and select desired output resolution from PC.

Notes



Notes



Avenview Warranty Certificate

AVENVIEW CORP. ("Avenview") warrants Avenview-branded product(s) contained in the original packaging against defects in materials and workmanship when used normally in accordance with Avenview's enclosed manual guidelines for a period of THREE (3) YEARS from the date of original retail purchase - Warranty Period. Avenview's published guidelines include but are not limited to information contained in technical specifications, user manuals and service communications.

LABOR: During the Warranty Period of THREE (3) YEARS, Avenview will repair or replace the product(s) at no cost using new or used parts equivalent to novel performance and reliability if the product(s) is determined to have abide by Avenview's published guidelines. Cost of Labor applicable to product(s) after Warranty Period. For labor costs, please contact support@avenview.com.

PARTS: During the Warranty Period of THREE (3) YEARS, Avenview will supply new or rebuilt replacements in exchange for defective parts of the product(s) at no cost if the product(s) is determined to have abide by Avenview's published guidelines. Cost of Parts applicable to product(s) after Warranty Period. For part(s) costs, please contact support@avenview.com.

To obtain Warranty: (a) proof of purchase in the form of a bill of sale or receipted invoice reflecting that the registered product(s) is within warranty period must be presented to obtain warranty service; (b) product(s) must be registered at time of purchase. Failure to do so will result in applicable parts and labor charges. Returning product(s) must be shipped in Avenview's original packaging or in packaging pertaining equal degree of protection to Avenview's. Both Avenview and purchaser are responsible for freight charges and brokerages when shipping the product(s) to the receiver.

NOT COVERED BY THIS WARRANTY

This warranty does not apply to any non-Avenview branded product(s); non-registered Avenview product(s). This warranty does not apply: (a) to cosmetic damage, including but not limited to scratches, dents and broken cords; (b) to damage caused by use with another product; (c) to damage caused by accident, abuse, misuse, liquid contact, fire, earthquake or other external cause; (d) to damage caused by operating the Avenview product(s) outside Avenview's manuals or guidelines; (e) to damage caused by service performed by anyone who is not a representative of Avenview or an Avenview authorized personnel; (f) to defects caused by normal wear and tear or otherwise due to the normal aging of the Avenview product(s), or (g) if any serial number has been removed or defaced from the Avenview product(s).

AVENVIEW IS NOT LIABLE FOR DIRECT, SPECIAL, INCIDENTAL OR CONSEQUENTIAL DAMAGES RESULTING FROM ANY BREACH OF WARRANTY OR CONDITION, OR UNDER ANY OTHER LEGAL THEORY, INCLUDING BUT NOT LIMITED TO LOSS OF USE; LOSS OF REVENUE; LOSS OF ACTUAL OR ANTICIPATED PROFITS (INCLUDING LOSS OF PROFITS ON CONTRACTS); LOSS OF THE USE OF MONEY; LOSS OF ANTICIPATED SAVINGS; LOSS OF BUSINESS; LOSS OF OPPORTUNITY; LOSS OF GOODWILL; LOSS OF REPUTATION; LOSS OF, DAMAGE TO, COMPROMISE OR CORRUPTION OF DATA; OR ANY INDIRECT OR CONSEQUENTIAL LOSS OR DAMAGE REPAIR OR REPLACEMENT AS PROVIDED UNDER THIS WARRANTY IS THE EXCLUSIVE REMEDY OF THE CONSUMER.

Some states do not allow the inclusion or limitation of incidental or consequential damages, or allow limitations on duration implements of the Warranty Period; therefore the above limitations or exclusions may not be applicable to you. This warranty gives you specific legal rights, and you may have other rights which vary from state to state.



1100 Military Rd., Kenmore, NY 14217
1.866.508.0269





AV Connectivity, Distribution And Beyond...

TECHNICAL SUPPORT

CONTACT US



Phone: 1 (866) 508 0269



Email: support@avenview.com



Avenview Canada

151 Esna Park Drive, Unit 11-12
Markham, ON L3R 3B1
Phone: +1 905 907 0525
Email: info@avenview.com
Sales: sales@avenview.com

Avenview USA

1100 Military Road
Kenmore, NY 14217
Phone: +1 716 218 4100 x223
Fax: +1 866 387 8764
Email: info@avenview.com

Avenview Europe

Phone: +31 085 2100 613
Email: info@avenview.eu

Avenview Asia

Email: wenxi@avenview.com.hk
Sales: sales@avenview.com.hk

Disclaimer

While every precaution has been taken in the preparation of this document, Avenview Inc. assumes no liability with respect to the operation or use of Avenview hardware, software or other products and documentation described herein, for any act or omission of Avenview concerning such products or this documentation, for any interruption of service, loss or interruption of business, loss of anticipatory profits, or for punitive, incidental or consequential damages in connection with the furnishing, performance, or use of the Avenview hardware, software, or other products and documentation provided herein.

Avenview Inc. reserves the right to make changes without further notice to a product or system described herein to improve reliability, function or design. With respect to Avenview products which this document relates, Avenview disclaims all express or implied warranties regarding such products, including but not limited to, the implied warranties of merchantability, fitness for a particular purpose, and non-infringement.